

**Part No. 060183-10, Rev. D
December 2004**

OmniSwitch 8800 Hardware Users Guide



www.alcatel.com

**This user guide documents OmniSwitch 8800
hardware, including chassis and associated components.
The specifications described in this guide are subject to change without notice.**

Copyright © 2004 by Alcatel Internetworking, Inc. All rights reserved. This document may not be reproduced in whole or in part without the express written permission of Alcatel Internetworking, Inc.

Alcatel[®] and the Alcatel logo are registered trademarks of Alcatel. Xylan[®], OmniSwitch[®], OmniStack[®], and Alcatel OmniVista[®] are registered trademarks of Alcatel Internetworking, Inc.

OmniAccess[™], Omni Switch/Router[™], PolicyView[™], RouterView[™], SwitchManager[™], VoiceView[™], WebView[™], X-Cell[™], X-Vision[™], and the Xylan logo are trademarks of Alcatel Internetworking, Inc.

This OmniSwitch product contains components which may be covered by one or more of the following U.S. Patents:

- U.S. Patent No. 6,339,830
- U.S. Patent No. 6,070,243
- U.S. Patent No. 6,061,368
- U.S. Patent No. 5,394,402
- U.S. Patent No. 6,047,024
- U.S. Patent No. 6,314,106
- U.S. Patent No. 6,542,507



**26801 West Agoura Road
Calabasas, CA 91301
(818) 880-3500 FAX (818) 880-3505
info@ind.alcatel.com**

**US Customer Support—(800) 995-2696
International Customer Support—(818) 878-4507
Internet—<http://eservice.ind.alcatel.com>**

Contents

	About This Guide	ix
	Supported Platforms	ix
	Who Should Read this Manual?	ix
	When Should I Read this Manual?	x
	What is in this Manual?	x
	What is Not in this Manual?	x
	How is the Information Organized?	xi
	Documentation Roadmap	xi
	Related Documentation	xiii
	User Manual CD	xiv
	Technical Support	xiv
Chapter 1	The OmniSwitch 8800	1-1
	Application Example	1-2
	Availability Features	1-3
	Hardware Redundancy	1-3
	Smart Continuous Switching	1-4
	Software Rollback	1-4
	Hot Swapping	1-5
	Hardware Monitoring	1-5
	Power Checking Sequence	1-6
Chapter 2	Chassis and Power Supplies	2-1
	In This Chapter	2-1
	Chassis Specifications	2-3
	Chassis Slot Numbering	2-6
	Viewing Chassis Slot Information	2-7
	Mounting the Switch	2-8
	Rack-Mounting	2-9
	Stand-Alone	2-12
	Power Supplies	2-13
	1375 Watt DC-to-DC Power Supply	2-15
	DC Power Supply Connection	2-16
	Connecting the DC Cable Harness to the Chassis Power Supply	2-16
	Connecting the DC Cable Harness to the DC Power Source	2-16

Power Supply Redundancy	2-17
Redundancy Defined	2-17
Adding a Power Supply	2-17
Hot Swapping a Power Supply	2-17
Permanently Removing a Power Supply	2-18
Installing a Power Supply	2-19
Removing a Power Supply	2-22
Power Cords	2-24
Redundant AC Circuit Recommendation	2-25
Grounding the Chassis	2-26
Temperature Management	2-26
Temperature Errors	2-27
Chassis Fan Trays	2-28
Monitoring Fan Tray Status	2-30
Fan Redundancy	2-30
Hot Swapping a Fan Tray	2-31
Removing a Front Fan Tray	2-31
Installing a New Front Fan Tray	2-32
Removing the Back Fan Tray	2-33
Installing the New Back Fan Tray	2-34
Chassis Airflow	2-35
Power Supply Fans	2-37
Blank Cover Panels and Chassis Airflow	2-38
Managing MAC Addresses on the Switch	2-39
MAC Range Guidelines	2-39
OS8800 MAC Range Specifications	2-40
VLAN Router Ports and MAC Address Allocation	2-41
Multiple MAC Router Mode	2-41
Enabling Single MAC Router Mode	2-41
Viewing Current Multiple MAC Router Mode Status	2-42

Chapter 3	Chassis Management Module (CMM)	3-1
	In This Chapter	3-1
	CMM Slot Locations	3-2
	CMM Front Panel	3-3
	Ethernet Management Port	3-4
	Access to the EMP	3-4
	EMP Cable Requirements	3-4
	Console/Modem Port	3-5
	Serial Connection to the Console/Modem Port	3-5
	Configuring X-ON/X-OFF Protocol	3-7
	Converting the Console Port to a Modem Port	3-7
	CMM Redundancy	3-9
	CMM Failover Sequence	3-9
	Synchronizing the Primary and Secondary CMMs	3-10

Hot Swapping CMMs	3-12
Module Presence Signalling	3-12
Hot Swap Requirements	3-12
Managing CMMs	3-13
Reloading a CMM	3-13
Switching the Primary and Secondary Roles	3-14
Monitoring CMMs	3-15
Front Panel LEDs	3-15
Accessing General CMM Information	3-15
CMM Hardware Information	3-15
Operating Status of CMM-Related Components	3-16
CLI Commands Supported on Both the Primary and Secondary CMMs	3-16
Chassis-Based MAC Address	3-17
Pinouts	3-18
Chapter 4	
Switch Fabric Module (SFM)	4-1
In This Chapter	4-1
SFM Slot Locations	4-2
SFM Front Panel	4-3
SFM Redundancy	4-4
SFM Failover Sequence	4-4
Adding and Removing SFM Modules	4-5
Using the Grounding Wrist Strap and Chassis Grounding Lug	4-5
Module Slot Positions	4-6
Adding a Module	4-7
Removing a Module	4-10
SFM Power Commands	4-13
Powering On an SFM	4-13
Powering Off an SFM	4-13
Setting an SFM to Standby	4-13
Monitoring SFM Modules	4-14
Front Panel LEDs	4-14
Accessing General SFM Information	4-15

Chapter 5	Network Interface (NI) Modules	5-1
	In This Chapter	5-1
	ENI Modules	5-3
	Additional Features	5-3
	OS8-ENI-C24 Front Panel	5-4
	GNI Modules	5-6
	OS8-GNI-C8 Front Panel	5-7
	OS8-GNI-U8 Front Panel	5-9
	OS8-GNI-U24/OS8-GNI2-U24 Front Panel	5-11
	MiniGBIC Specifications	5-13
	Installing MiniGBIC Connectors	5-14
	Removing MiniGBIC Connectors	5-15
	OS8-GNI-C24/OS8-GNI2-C24 Front Panel	5-16
	10GNI Modules	5-18
	OS8-10GNI-UR1 Port Redundancy	5-19
	Unsupported Software Features	5-19
	OS8-10GNI-UR1 Front Panel	5-20
	Xenpak Specifications	5-22
	Installing Xenpak Connectors	5-23
	Removing Xenpak Connectors	5-25
	Smart Continuous Switching	5-26
	Module Priorities During Boot Sequence	5-26
	Managing NI Modules	5-26
	Turning Power On or Off for a Specific NI Module	5-26
	Individual NI Reload	5-26
	Monitoring NI Modules	5-27
	Front Panel LEDs	5-27
	Accessing General NI Information	5-27
	Hot Swapping NI Modules	5-28
	Removing and Adding Modules	5-29
	Using the Grounding Wrist Strap and Chassis Grounding Lug	5-29
	Module Types and Slot Positions	5-30
	Removing a Module	5-30
	Adding a Module	5-32
	Pinouts	5-34
	Handling Fiber and Fiber Optic Connectors	5-35

Appendix A	Regulatory Compliance and Safety Information	A-1
	Declaration of Conformity: CE Mark	A-1
	Standards Compliance	A-2
	FCC Class A, Part 15	A-3
	Canada Class A Statement	A-3
	JATE	A-3
	CISPR22 Class A warning	A-3
	VCCI	A-4
	Class A Warning for Taiwan and Other Chinese Markets	A-4
	Translated Safety Warnings	A-5
	Chassis Lifting Warning	A-5
	Blank Panels Warning	A-5
	Electrical Storm Warning	A-5
	Installation Warning	A-6
	Invisible Laser Radiation Warning	A-6
	Lithium Battery Warning	A-7
	Operating Voltage Warning	A-7
	Power Disconnection Warning	A-8
	Proper Earthing Requirement Warning	A-8
	Read Important Safety Information Warning	A-9
	Restricted Access Location Warning	A-9
	Wrist Strap Warning	A-10
	Instrucciones de seguridad en español	A-11
	Advertencia sobre el levantamiento del chasis	A-11
	Advertencia de las tapaderas en blanco	A-11
	Advertencia en caso de tormenta eléctrica	A-11
	Advertencia de instalación	A-11
	Advertencia de radiación láser invisible	A-11
	Advertencia de la batería de litio	A-11
	Advertencia sobre la tensión de operación	A-11
	Advertencia sobre la desconexión de la fuente	A-11
	Advertencia sobre una apropiada conexión a tierra	A-12
	Leer “información importante de seguridad”	A-12
	Advertencia de acceso restringido	A-12
	Advertencia de pulsera antiestática	A-12
	Clase de seguridad	A-12
	Advertencia de fuentes de poder	A-12
	Index	Index-1

About This Guide

This *OmniSwitch 8800 Hardware Users Guide* describes your switch hardware components and basic switch hardware procedures.

Supported Platforms

This information in this guide applies to the following products:

- OmniSwitch 8800

The OmniSwitch 8800 includes 18 slots for high performance 10/100 Ethernet, 1 Gbps Gigabit Ethernet, and 10 Gbps Gigabit NI modules.

Unsupported Platforms

The information in this guide does not apply to the following products:

- OmniSwitch (original version with no numeric model name)
- OmniSwitch 6624
- OmniSwitch 6648
- OmniSwitch 6600-U24
- OmniSwitch 6600-P24
- OmniSwitch 6602-24
- OmniSwitch 6602-48
- OmniSwitch 7700
- OmniSwitch 7800
- Omni Switch/Router
- OmniStack
- OmniAccess

Who Should Read this Manual?

The audience for this users guide is network administrators and IT support personnel who need to configure, maintain, and monitor switches and routers in a live network. However, anyone wishing to gain knowledge on the OmniSwitch 8800 hardware will benefit from the material in this guide.

When Should I Read this Manual?

Read this guide as soon as you are ready to familiarize yourself with your switch hardware components. You should have already stepped through the first login procedures and read the brief hardware overviews in the *OmniSwitch 8800 Getting Started Guide*.

You should already be familiar with the very basics of the switch hardware, such as module LEDs and module installation procedures. This manual will help you understand your switch hardware components (chassis, cooling fans, power supplies, Network Interface modules, Switch Fabric Modules, Chassis Management Modules) in greater depth.

What is in this Manual?

This users guide includes the following hardware-related information:

- Descriptions of “Availability” features.
- Technical specifications for chassis, power supplies, Network Interface (NI) modules, and Chassis Management Modules (CMMs).
- Power supply requirements.
- The dynamics of chassis airflow, including detailed illustrations of proper and improper airflow configurations.
- Hot swapping power supplies, fan trays, Network Interface (NI) modules, and Chassis Management Modules (CMMs).
- Installation and removal procedures for power supplies, fan trays, Network Interface (NI) modules, Chassis Management Modules (CMMs), and Switch Fabric Modules (SFMs).
- Detailed illustrations and LED descriptions for power supplies, Network Interface (NI) modules, Chassis Management Modules (CMMs), and Switch Fabric Modules (SFMs).
- CMM redundancy
- SFM redundancy
- Hardware-related Command Line Interface (CLI) commands

What is Not in this Manual?

The descriptive and procedural information in this manual focuses on switch hardware. It includes information on some CLI commands that pertain directly to hardware configuration, but it is not intended as a software users guide. There are several OmniSwitch 8800 users guides that focus on switch software configuration. Consult those guides for detailed information and examples for configuring your switch software to operate in a live network environment. See [“Documentation Roadmap” on page xi](#) and [“Related Documentation” on page xiii](#) for further information on software configuration guides available for your switch.

How is the Information Organized?

Each chapter in this guide focuses on a specific hardware component, such as the Chassis Management Module (CMM), or a set of hardware components. All descriptive, technical specification, and procedural information for a hardware component can be found in the chapter dedicated to that component.

Documentation Roadmap

The OmniSwitch user documentation suite was designed to supply you with information at several critical junctures of the configuration process. The following section outlines a roadmap of the manuals that will help you at each stage of the configuration process. Under each stage, we point you to the manual or manuals that will be most helpful to you.

Stage 1: Using the Switch for the First Time

Pertinent Documentation: *OmniSwitch 8800 Getting Started Guide*
Release Notes

A hard-copy *OmniSwitch 8800 Getting Started Guide* is included with your switch; this guide provides all the information you need to get your switch up and running the first time. This guide provides information on unpacking the switch, rack mounting the switch, installing NI modules, unlocking access control, setting the switch's IP address, and setting up a password. It also includes succinct overview information on fundamental aspects of the switch, such as hardware LEDs, the software directory structure, CLI conventions, and web-based management.

At this time you should also familiarize yourself with the Release Notes that accompanied your switch. This document includes important information on feature limitations that are not included in other user guides.

Stage 2: Gaining Familiarity with Basic Switch Functions

Pertinent Documentation: *OmniSwitch 8800 Hardware Users Guide*
OmniSwitch 7700/7800/8800 Switch Management Guide

Once you have your switch up and running, you will want to begin investigating basic aspects of its hardware and software. Information about switch hardware is provided in the *OmniSwitch 8800 Hardware Users Guide*. This guide provides specifications, illustrations, and descriptions of all hardware components, such as chassis, power supplies, Chassis Management Modules (CMMs), Switch Fabric Modules (SFMs), Network Interface (NI) modules, and cooling fans. It also includes steps for common procedures, such as removing and installing switch components.

The *OmniSwitch 7700/7800/8800 Switch Management Guide* is the primary users guide for the basic software features on a single switch. This guide contains information on the switch directory structure, basic file and directory utilities, switch access security, SNMP, and web-based management. It is recommended that you read this guide before connecting your switch to the network.

Stage 3: Integrating the Switch Into a Network

Pertinent Documentation: *OmniSwitch 7700/7800/8800 Network Configuration Guide*
OmniSwitch 7700/7800/8800 Advanced Routing Configuration Guide

When you are ready to connect your switch to the network, you will need to learn how the OmniSwitch implements fundamental software features, such as 802.1Q, VLANs, Spanning Tree, and network routing protocols. The *OmniSwitch 7700/7800/8800 Network Configuration Guide* contains overview information, procedures, and examples on how standard networking technologies are configured in the OmniSwitch 8800.

The *OmniSwitch 7700/7800/8800 Advanced Routing Configuration Guide* includes configuration information for networks using advanced routing technologies (OSPF and BGP) and multicast routing protocols (DVMRP and PIM-SM).

Anytime

The *OmniSwitch CLI Reference Guide* contains comprehensive information on all CLI commands supported by the switch. This guide includes syntax, default, usage, example, related CLI command, and CLI-to-MIB variable mapping information for all CLI commands supported by the switch. This guide can be consulted anytime during the configuration process to find detailed and specific information on each CLI command.

Related Documentation

The following are the titles and descriptions of all the OmniSwitch 8800 user manuals:

- *OmniSwitch 8800 Getting Started Guide*

Describes the hardware and software procedures for getting an OmniSwitch 8800 up and running. Also provides information on fundamental aspects of OmniSwitch software architecture.

- *OmniSwitch 8800 Hardware Users Guide*

Complete technical specifications and procedures for all OmniSwitch 8800 chassis, power supplies, fans, Network Interface (NI) modules, and Switch Fabric Modules (SFMs).

- *OmniSwitch CLI Reference Guide*

Complete reference to all CLI commands supported on the OmniSwitch 8800. Includes syntax definitions, default values, examples, usage guidelines, and CLI-to-MIB variable mappings.

- *OmniSwitch 7700/7800/8800 Switch Management Guide*

Includes procedures for readying an individual switch for integration into a network. Topics include the software directory architecture, image rollback protections, authenticated switch access, managing switch files, system configuration, using SNMP, and using web management software (WebView).

- *OmniSwitch 7700/7800/8800 Network Configuration Guide*

Includes network configuration procedures and descriptive information on all the major software features and protocols included in the base software package. Chapters cover Layer 2 information (Ethernet and VLAN configuration), Layer 3 information (routing protocols, such as RIP and IPX), security options (authenticated VLANs), Quality of Service (QoS), link aggregation, and server load balancing.

- *OmniSwitch 7700/7800/8800 Advanced Routing Configuration Guide*

Includes network configuration procedures and descriptive information on all the software features and protocols included in the advanced routing software package. Chapters cover multicast routing (DVMRP and PIM-SM), Open Shortest Path First (OSPF), and Border Gateway Protocol (BGP).

- *Technical Tips, Field Notices*

Includes information published by Alcatel's Customer Support group.

- *Release Notes*

Includes critical Open Problem Reports, feature exceptions, and other important information on the features supported in the current release and any limitations to their support.

User Manual CD

All user guides for the OmniSwitch 8800 are included on the User Manual CD that accompanied your switch. This CD also includes user guides for other Alcatel data enterprise products. In addition, it contains a stand-alone version of the on-line help system that is embedded in the OmniVista network management application.

Besides the OmniVista documentation, all documentation on the User Manual CD is in PDF format and requires the Adobe Acrobat Reader program for viewing. Acrobat Reader freeware is available at www.adobe.com.

Note. In order to take advantage of the documentation CD's global search feature, it is recommended that you select the option for *searching PDF files* before downloading Acrobat Reader freeware.

To verify that you are using Acrobat Reader with the global search option, look for the following button in the toolbar:



Note. When printing pages from the documentation PDFs, de-select Fit to Page if it is selected in your print dialog. Otherwise pages may print with slightly smaller margins.

Technical Support

An Alcatel service agreement brings your company the assurance of 7x24 no-excuses technical support. You'll also receive regular software updates to maintain and maximize your Alcatel product's features and functionality and on-site hardware replacement through our global network of highly qualified service delivery partners. Additionally, with 24-hour-a-day access to Alcatel's Service and Support web page, you'll be able to view and update any case (open or closed) that you have reported to Alcatel's technical support, open a new case or access helpful release notes, technical bulletins, and manuals. For more information on Alcatel's Service Programs, see our web page at www.ind.alcatel.com, call us at 1-800-995-2696, or email us at support@ind.alcatel.com.

1 The OmniSwitch 8800

The 18-slot OmniSwitch 8800 (OS8800) switch offers high performance 10/100 Ethernet and Gigabit Ethernet capabilities, as well as embedded server load balancing for enterprise requirements. It provides non-blocking Gigabit Ethernet connectivity, carrier-class availability, multi-layer security, and intelligent switching and routing services—all at wire speed. Both half duplex and full duplex are supported on all 10/100 Ethernet ports; full duplex is supported on the Gigabit and 10 Gigabit Ethernet ports.

Switching Fabric

The 18-slot OS8800 offers up to 384 10/100 Ethernet ports, up to 128 wire-rate Gigabit Ethernet ports, up to 384 high-density Gigabit Ethernet ports, and up to 16 redundant 10 Gigabit Ethernet ports. The OS8800 has a fabric capacity of 512 Gbps and throughput of 240 Mbps.

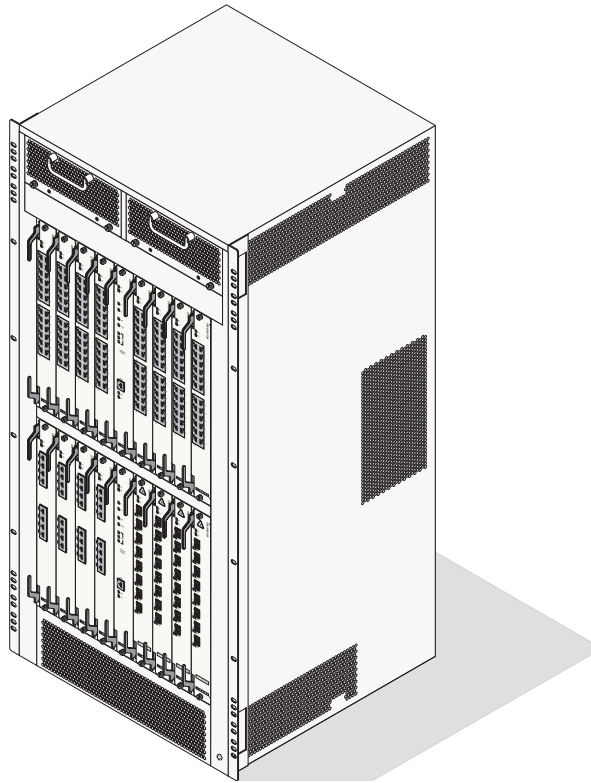

OmniSwitch 8800 Chassis

Application Example

The following application example shows one of the many ways OmniSwitch 8800 switches can be used in an Enterprise network setting.

- Core Switch.** In this example, an OS8800 is used as the core switch. Because the example network has a high-speed 10 Gigabit Ethernet backbone, the Network Interface (NI) cards in the chassis will use 10 Gigabit Ethernet Network Interface (10GNI) modules. The core switch connects to OmniSwitch 7700 and OmniSwitch 6648 switches in wiring closets as well as the company server farm and an OmniPCX, offering effective voice-data convergence.

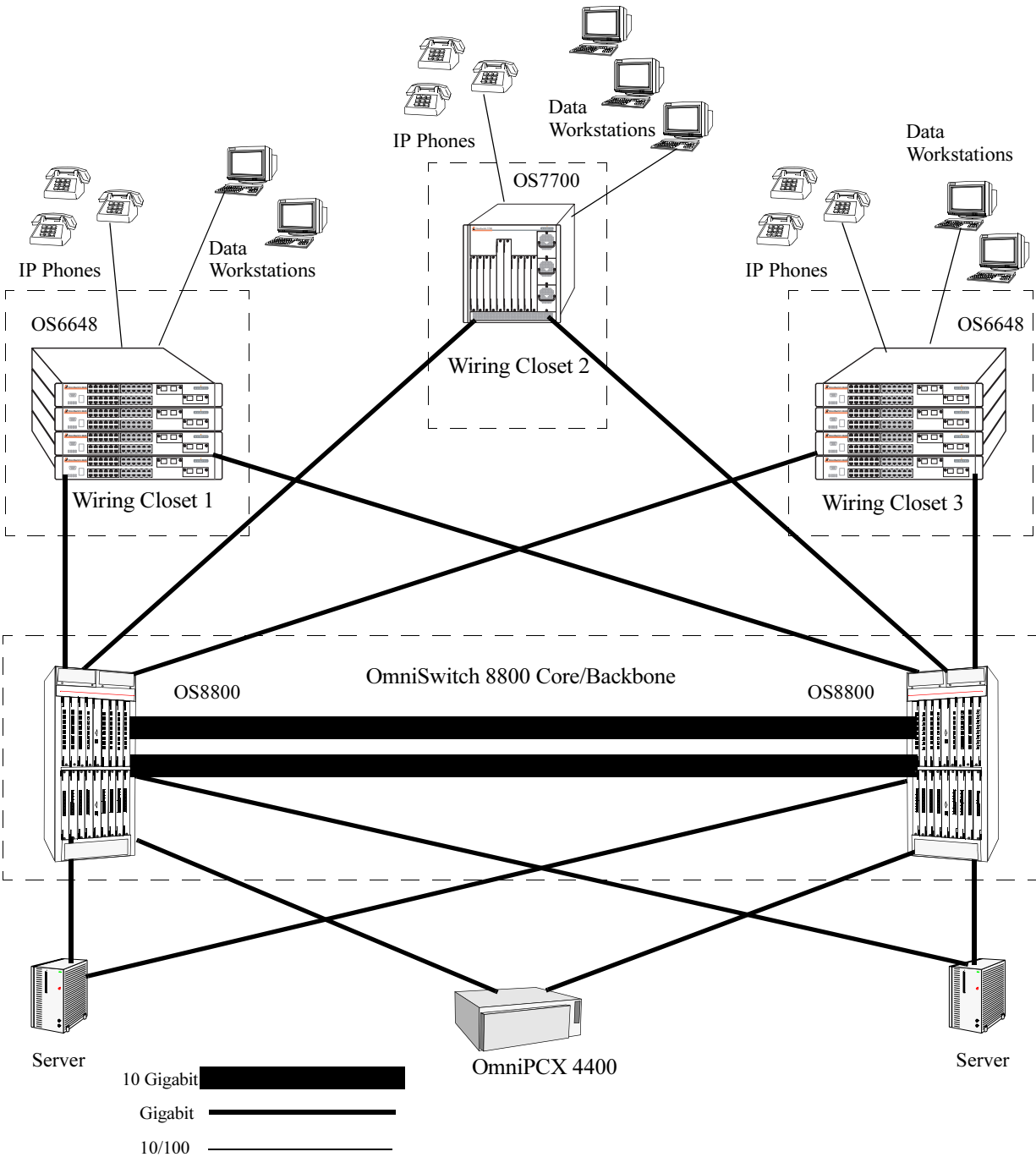

Availability Features

The switch provides a broad variety of *Availability* features. Availability features are hardware- and software-based safeguards that help prevent the loss of data flow in the unlikely event of a subsystem failure. In addition, some Availability features allow you to maintain or replace hardware components without powering off your switch or interrupting switch operations. Combined, these features provide added resiliency and help ensure that your switch is consistently available for your day-to-day network operations.

Hardware-related Availability features include:

- **Hardware Redundancy**
- **Smart Continuous Switching**
- **Software Rollback**
- **Hot Swapping**
- **Hardware Monitoring**
- **Power Checking Sequence**

Information on software-related availability is provided in the *OmniSwitch 7700/7800/8800 Switch Management Guide* and the *OmniSwitch 7700/7800/8800 Network Configuration Guide*. Refer to the corresponding feature chapter (e.g., VRRP).

Hardware Redundancy

Hardware redundancy refers to backup hardware components. If primary hardware components fail or go offline for any reason, the redundant hardware automatically assumes the primary hardware functions (this is also referred to as *failover*). The following components offer redundancy:

- Chassis Management Modules (CMMs)
- Switch Fabric Modules (SFMs)
- Power Supplies
- Fan Units
- MAC EEPROM

Note. Redundancy is a key Availability feature; it is recommended that you install redundant hardware components in your switch whenever possible.

For detailed information on CMM redundancy, refer to [Chapter 3, “Chassis Management Module \(CMM\).”](#) For detailed information on SFM redundancy, refer to [Chapter 4, “Switch Fabric Module \(SFM\).”](#) For information on power supply and fan redundancy, refer to [Chapter 2, “Chassis and Power Supplies.”](#)

Smart Continuous Switching

In redundant CMM configurations, the switch provides support for NIs during failover. In other words, if the primary CMM fails or goes offline for any reason, NI modules will continue data transmission and routing functions during the secondary CMM's takeover process. This Availability feature is referred to as *Smart Continuous Switching*.

Incoming Layer 2 packets will continue to be sent to the appropriate egress port during failover. Known routes will also be supported. (Note, however, that the NI cannot learn new routes without CMM support. Any new route information will be ignored.) Spanning Tree will continue handling BPDUs received on the switch ports, as well as port link up and down states. The Spanning Tree topology will not be disrupted.

Note. Smart Continuous Switching is designed to maintain data flow only during CMM failover and is *not* intended to support long-term data flow. If both the primary and secondary CMMs go offline or are removed from the chassis, switch operations (including all NI support) will be disabled.

For more information on CMM redundancy and the failover process, refer to [Chapter 3, “Chassis Management Module \(CMM\).”](#)

Software Rollback

Software rollback (also referred to as *image rollback*) essentially allows the switch to return to a prior “last known good” version of software in the event of a system software problem. The CMM controls software rollback through its resilient directory structure design (i.e., **/flash/working** and **/flash/certified**).

For detailed information on the software rollback feature, as well as the switch's **/flash/working** and **/flash/certified** directories, refer to the “Managing CMM Directory Contents” chapter in the *OmniSwitch 7700/7800/8800 Switch Management Guide*.

Hot Swapping

Hot swapping refers to the action of adding, removing, or replacing certain hardware components without powering off your switch and disrupting other components in the chassis. This feature greatly facilitates hardware upgrades and maintenance and also allows you to easily replace components in the unlikely event of hardware failure. The following hardware components can be hot swapped:

- Chassis Management Modules (CMMs)
- Ethernet Network Interface modules (ENIs)
- Gigabit Ethernet Network Interface modules (GNIs)
- 10 Gigabit Ethernet Network Interface modules (10GNIs)
- Power supplies
- Fan tray

Hot Swapping Non-Redundant Management Modules and Power Supplies. If there is only one CMM or power supply installed in the chassis and either of these components is removed or replaced, all switch functions will be stopped until a replacement is installed.

Hot Swapping NI Modules. It is recommended that you hot swap NIs of the same type (e.g., OS8-GNI-U8) whenever possible. Otherwise, the network configuration may be adversely affected.

For information on hot swapping CMMs, refer to [Chapter 3, “Chassis Management Module \(CMM\).”](#) For information on hot swapping NI modules, refer to [Chapter 5, “Network Interface \(NI\) Modules.”](#) For information on hot swapping power supplies and fan trays, refer to [Chapter 2, “Chassis and Power Supplies.”](#)

Hardware Monitoring

Automatic Monitoring

Automatic monitoring refers to the switch’s built-in sensors that automatically monitor operations. The majority of automatic monitoring is provided by the CMM. If an error is detected (e.g., over-threshold temperature), the CMM immediately sends a trap to the user. The trap is displayed on the console in the form of a text error message. (In the case of an over-threshold temperature condition, the CMM displays an amber TEMP LED in addition to sending a trap.)

LEDs

LEDs, which provide visual status information, are provided on the CMM, NI, SFM, and power supply front panels. LEDs are used to indicate conditions such as hardware and software status, temperature errors, link integrity, data flow, etc. For detailed LED descriptions, refer to the corresponding hardware component chapter (e.g., “Network Interface (NI) Modules”).

User-Driven Monitoring

User-driven hardware monitoring refers to CLI commands that are entered by the user in order to access the current status of hardware components. The user enters “show” commands that output information to the console. Show commands for all features are described in detail in the *OmniSwitch CLI Reference Guide*.

Power Checking Sequence

The power checking sequence is another built-in Availability feature. This feature helps regulate power in the switch whenever the switch is booted or an NI module is installed in the chassis.

The sequence is a joint effort among the CMM, the SFMs, the NI modules, and the power supplies. During the boot sequence, the primary CMM automatically compares the power consumption required by installed NIs with the power available from the power supplies. If there is not adequate power to support all NIs, the CMM will power on only the supported number of NIs, starting from the first NI slot position.

Important. During the power checking sequence, CMMs receive priority and are always powered on first. SFMs are powered on next, then NI modules are powered on sequentially by slot position. In other words, the NI in slot 1 is powered on, then slot 2, then slot 3, etc. For information on slot positions, refer to [Chapter 2, “Chassis and Power Supplies.”](#)

Installing a New NI into a Running Chassis

When an NI module is installed in the chassis, only a small portion of the circuitry is initially powered up. The CMM immediately reads the incoming module's ID and determines how much power the module will require. If the number of power supplies installed in the chassis can provide sufficient power, the CMM turns on the incoming module. If the number of installed power supplies cannot provide sufficient power, the incoming NI will remain powered off.

2 Chassis and Power Supplies

The 18-slot OmniSwitch 8800 (OS8800) chassis provides 16 slots for Network Interface (NI) modules, 2 slots for Chassis Management Modules (CMMs), five slots for Switch Fabric Modules (SFMs), 4 slots for power supplies, two slots for chassis-cooling fan trays, and one slot for a fabric-cooling fan tray. OS8800 chassis provide important availability features, such as hardware redundancy and hot swapping.

In This Chapter

This chapter provides specifications and descriptions of all OmniSwitch 8800 chassis components. In addition, procedures to set up chassis components and procedures to monitor chassis components using Command Line Interface (CLI) commands are also provided. Topics include:

- Chassis specifications on [page 2-3](#)
- Chassis slot numbering on [page 2-6](#)
- Switch mounting information on [page 2-8](#)
- Power supplies and power supply redundancy beginning on [page 2-13](#)
- Temperature management on [page 2-26](#)
- Chassis fan trays beginning on [page 2-28](#)
- Monitoring the chassis components via the Command Line Interface (CLI) on [page 2-7](#), [page 2-17](#), [page 2-26](#), and [page 2-30](#).

Note. You can also monitor all chassis components and manage many chassis features such as temperature management with WebView, Alcatel's embedded web-based device management application. WebView is an interactive and easy-to-use GUI that can be launched from OmniVista or a web browser. Please refer to WebView's online documentation for more information.

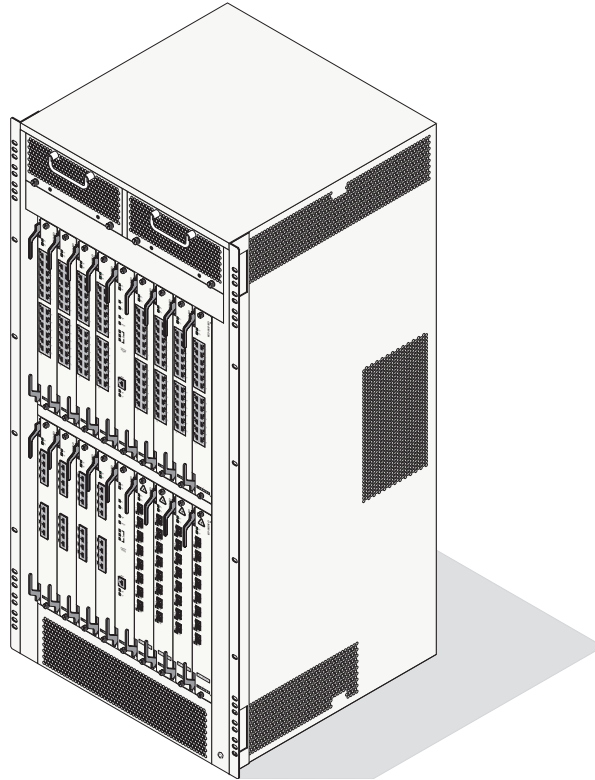

OmniSwitch 8800 Chassis

Chassis Specifications

The OmniSwitch 8800 is a high performance switch offering 16 slots for Ethernet, Gigabit Ethernet, and/or 10 Gigabit Ethernet Network Interface (NI) modules. An additional two slots are reserved for primary and redundant Chassis Management Modules (CMMs).

On the back of the chassis five slots are reserved for Switch Fabric Modules (SFMs). The OmniSwitch 8800 supports a maximum of four power supplies.

Note. Power supply requirements are based on the number of NIs installed in the chassis. Refer to [“Power Supplies” on page 2-13](#) for important information on power supplies and power supply redundancy.

The following illustrations outline the major components of the OmniSwitch 8800 switch.

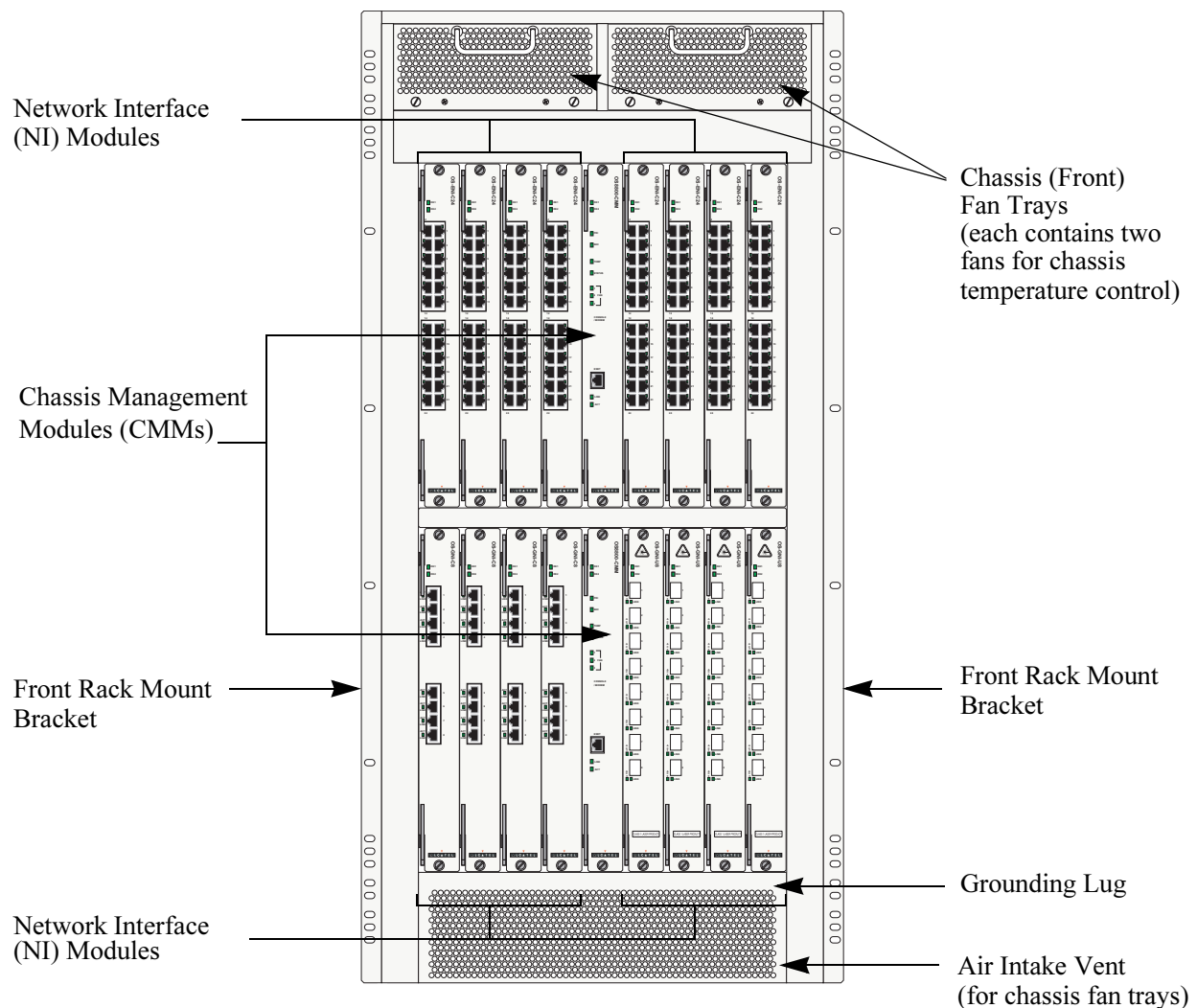

OmniSwitch 8800 Front View

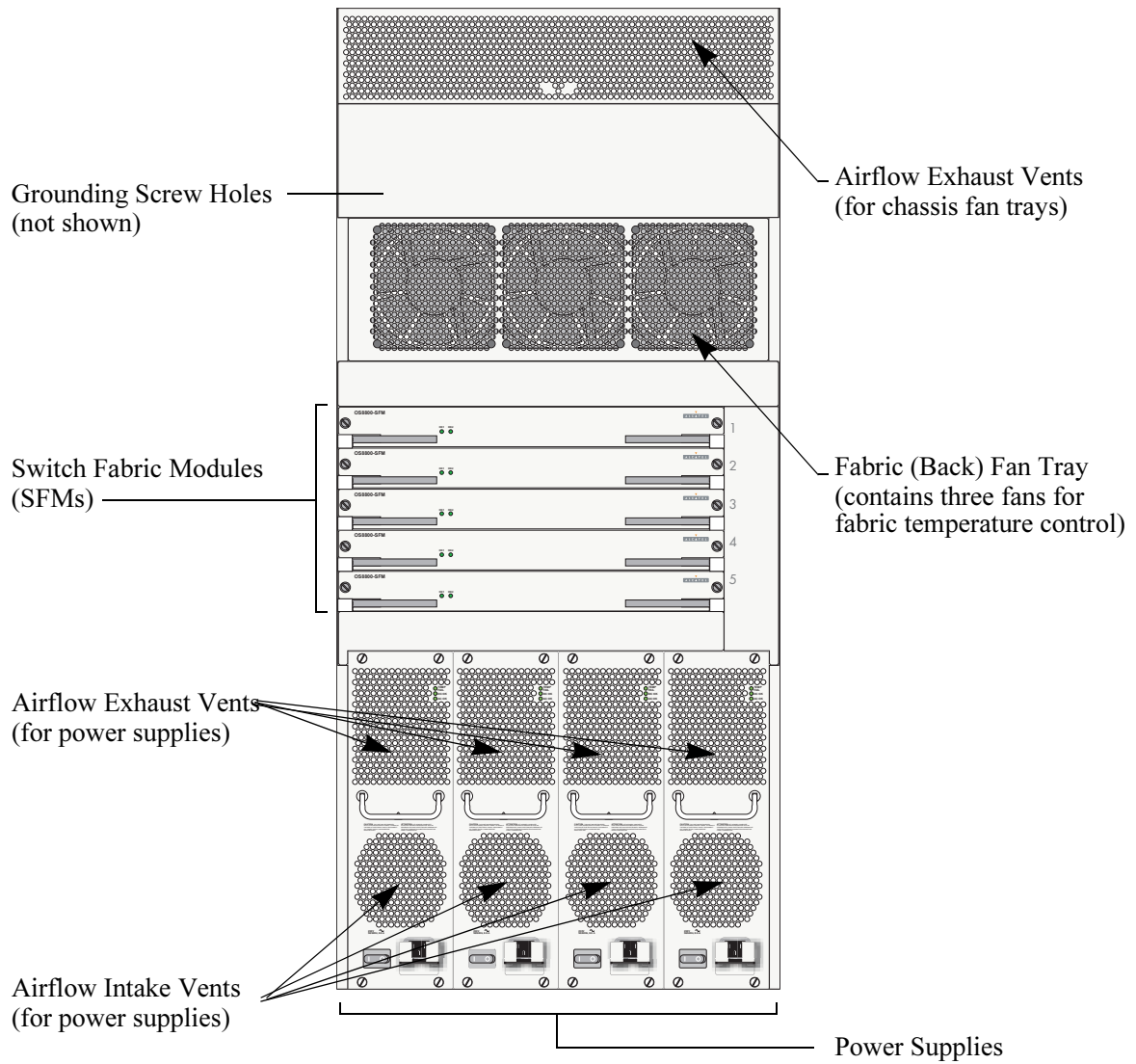

OmniSwitch 8800 Back View

OmniSwitch 8800 Technical Specifications

Total copper 10/100 Ethernet ports available	384 (Fully-populated with OS8-ENI-C24 modules. No other NI module types installed.)
Total copper wire-rate Gigabit Ethernet ports available	128 (Fully-populated with OS8-GNI-C8 modules. No other NI module types installed.)
Total fiber wire-rate Gigabit Ethernet ports available	128 (Fully-populated with OS8-GNI-U8 modules, with each GNI containing eight MiniGBICs. No other NI modules installed.)
Total fiber high-density Gigabit Ethernet ports available	384 (Fully-populated with OS8-GNI-U24 modules, with each GNI containing 24 MiniGBICs. No other NI modules installed.)
Total copper high-density Gigabit Ethernet ports available	384 (Fully-populated with OS8-GNI-C24 modules. No other NI modules installed.)
Total fiber wire-rate 10 Gigabit Ethernet ports available	16 (Fully-populated with OS8-10GNI-UR1 modules. No other NI modules installed.)
Total slots available for network interface (NI) modules	16
Total slots available for CMMs	2
Total slots available for SFMs	5
Total bays for power supplies	4
Total bays for fan trays	3 (2 in front and 1 in back)
Fabric capacity	512 Gigabits per second (throughput of 240 Mpps)
Maximum Current draw	57.3 Amps at 24 volts
Maximum Power	1375 Watts
Chassis Width	17.40 inches (44.20 cm) (Brackets are included for 19-inch racks. Optional brackets are available for 23-inch racks)
Height	38.40 inches (97.54 cm)
Height (rack units)	22 RU
Overall Depth	17.30 inches (43.94 cm)
Weight (fully loaded)	approximately 220 lbs (100 kg)
Storage Temperature	-4 ~ 158 °F (-20 ~ 70 °C)
Operating Temperature	32 ~ 113 °F (0 ~ 45 °C)
Maximum heat dissipation	12564 BTU per hour
Humidity	0 to 95% (Non-condensing)
Operating Altitude	Sea level to 10000 feet (3 km)

Chassis Slot Numbering

The term *slot* refers to the position which CMM, SFM, or NI modules are installed in chassis. CMM slot positions are designated as Slot A and Slot B. NI Slot numbers range from 1 to 16. SFM slot numbers range from 1 to 5, numbered top to bottom. Power supply bays are also given specific slot numbers. Power supply slot numbers are designated PS-1 through PS-4, from left to right.

Individual fans in the three fan trays are numbered by software (which can be displayed with the **show fan** command) as Fan-1 and Fan-2 in the left front fan tray, Fan-3 and Fan-4 in the right front fan tray, and Fan-5, Fan-6, and Fan-7 in the rear fan tray. On the CMM there are three LEDs labeled **FAN 1** (left front fan tray), **FAN 2** (right front fan tray), and **FAN 3** (rear fan tray) that provide status information for the fans. See Chapter 3, “Chassis Management Module (CMM),” for more information on fan tray LEDs.

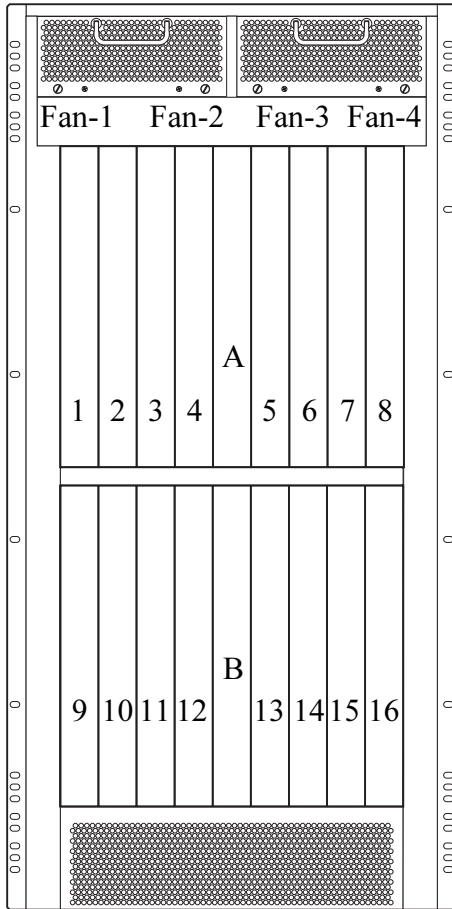

Front View

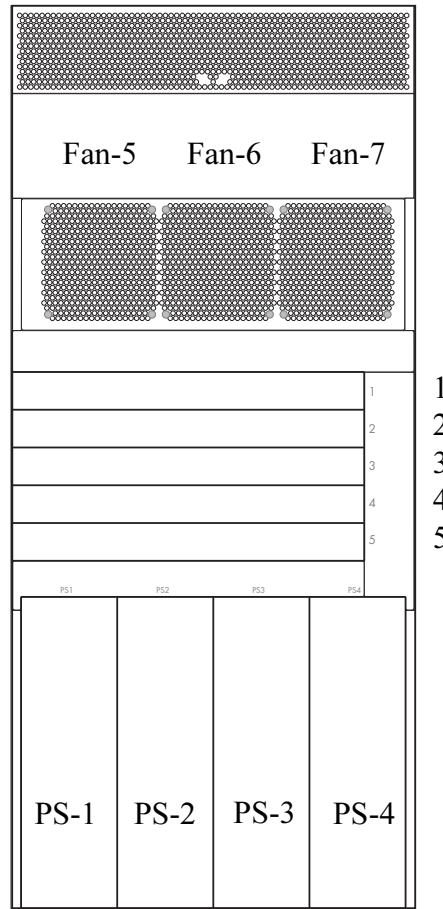

Back View

OmniSwitch 8800 Slot Numbering

Viewing Chassis Slot Information

To view basic slot information via the CLI, enter the **show module** command at the CLI prompt:

```
-> show module 3
```

Slot	Part-Number	Serial #	HW Rev	Mfg Date	Model Name
NI-3	902055-10	2146008P	106	APR 11 2002	OS8-ENI-C24

To view more detailed slot information, use the **show module long** form of this command. For example:

```
-> show module long 3
Module in slot 3
Model Name: OS8-ENI-C24 ,
Description: 24pt TP Mod,
Part Number: 902055-10,
Hardware Revision: 106,
Serial Number: 2146008P,
Manufacture Date: APR 11 2002,
Firmware Version: 5,
Admin Status: POWER ON,
Operational Status: UP,
Power Consumption: 44,
Power Control Checksum: 0x808,
MAC Address: 00:d0:95:77:4b:f4,
ASIC - Physical: 0x1901 0x001e 0x001e 0x001e
```

Mounting the Switch

Two people are required when lifting the OS8800 chassis. Due to its weight, lifting the chassis unassisted can cause personal injury. If you need to move the switch, be sure to power it down and remove all modules and power supplies. For instructions on removing CMM or NI modules, refer to [Chapter 5, “Network Interface \(NI\) Modules.”](#) For instructions on removing SFMs, refer to [Chapter 4, “Switch Fabric Module \(SFM\).”](#) For instructions on removing power supplies, refer to [“Removing a Power Supply” on page 2-22.](#)

Note. Due to their weight and airflow requirements, OS8800 switches cannot be wall-mounted.

Airflow Considerations

Be sure that your switch is placed in a well-ventilated, static-free environment. Always allow adequate clearance at the front and sides of the switch, as well as behind the switch’s fan trays (located at the top-front and middle-rear of the chassis). The following top-view diagram shows recommended minimum clearances for adequate airflow.

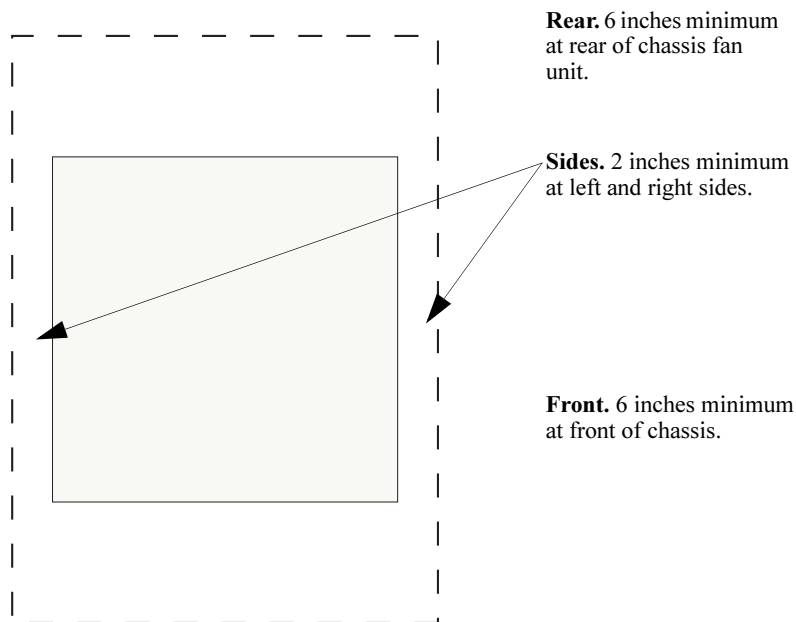

Chassis Top View

Note. Never obstruct the air intake vents located at the bottom-left, bottom-front, bottom-right, and middle-right sides of the chassis *or* the fan unit’s air output vents located at the top-left, top-front, top-right, top-rear, and middle-rear of the chassis. Clearance is not required at the top and bottom of the chassis.

Power Supply Considerations

The power source socket-outlet must be installed near the chassis and must be easily accessible.

Rack-Mounting

Refer to the important guidelines below before installing the OmniSwitch 8800 chassis in a rack.

- Be sure that all modules and power supplies are removed before rack-mounting the switch. For instructions on removing CMM or NI modules, refer to [Chapter 5, “Network Interface \(NI\) Modules.”](#) For instructions on removing power supplies, refer to [“Removing a Power Supply” on page 2-22.](#)
- Rack-mounting the chassis requires three people—two people to hold the chassis and position it in the rack and a third person to secure the chassis to the rack using the attachment screws.
- The chassis is supplied with two (2) 19-inch rack-mounting brackets.
- Alcatel does not provide rack-mount screws. Use the screws supplied by the rack vendor.
- To prevent a rack from becoming top heavy, it is recommended that you install the switch at the bottom of the rack whenever possible.
- If you are installing the switch in a relay rack, be sure to install and secure the rack per the rack manufacturer’s specifications.
- Refer to [page 2-8](#) for important chassis airflow recommendations before installing.

To rack-mount the switch, follow the steps below:

- 1** Using the rack-mounting brackets as a template, mark the holes on the rack where the chassis is to be installed.
- 2** Attach one rack-mounting bracket to the front end of the chassis using the Phillips-head screws that came with the chassis. See the figure on the following page for the positioning and placement of these brackets and screws.

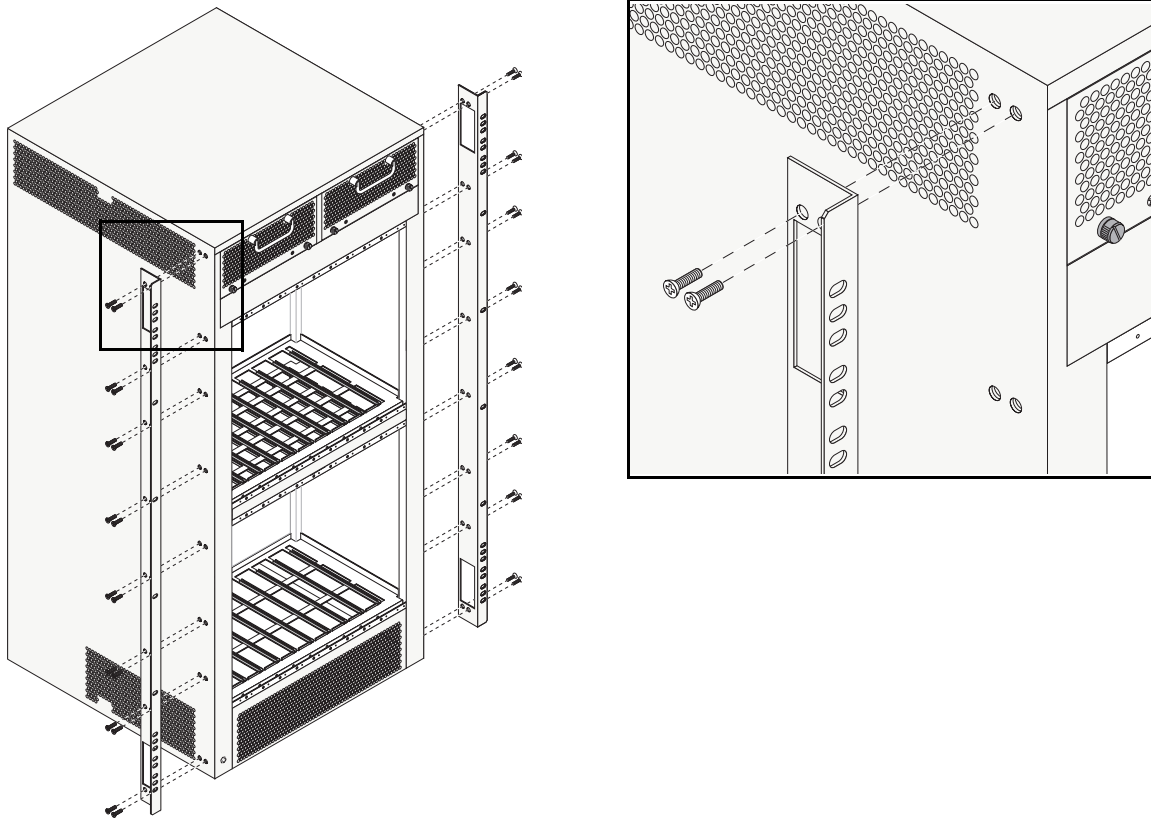

Attaching Rack-Mounting Brackets

- 3** Attach the second bracket to the opposite front side of the chassis using the remaining screws.
- 4** Using two people, lift and position the chassis until the rack-mount brackets are flush with the rack post.
- 5** Align the holes in the brackets with the rack holes you marked in step 1.

- 6** Once the holes are aligned, use a third person to insert an attachment screw through the *bottom hole on each bracket*. Tighten both screws until they are secure.

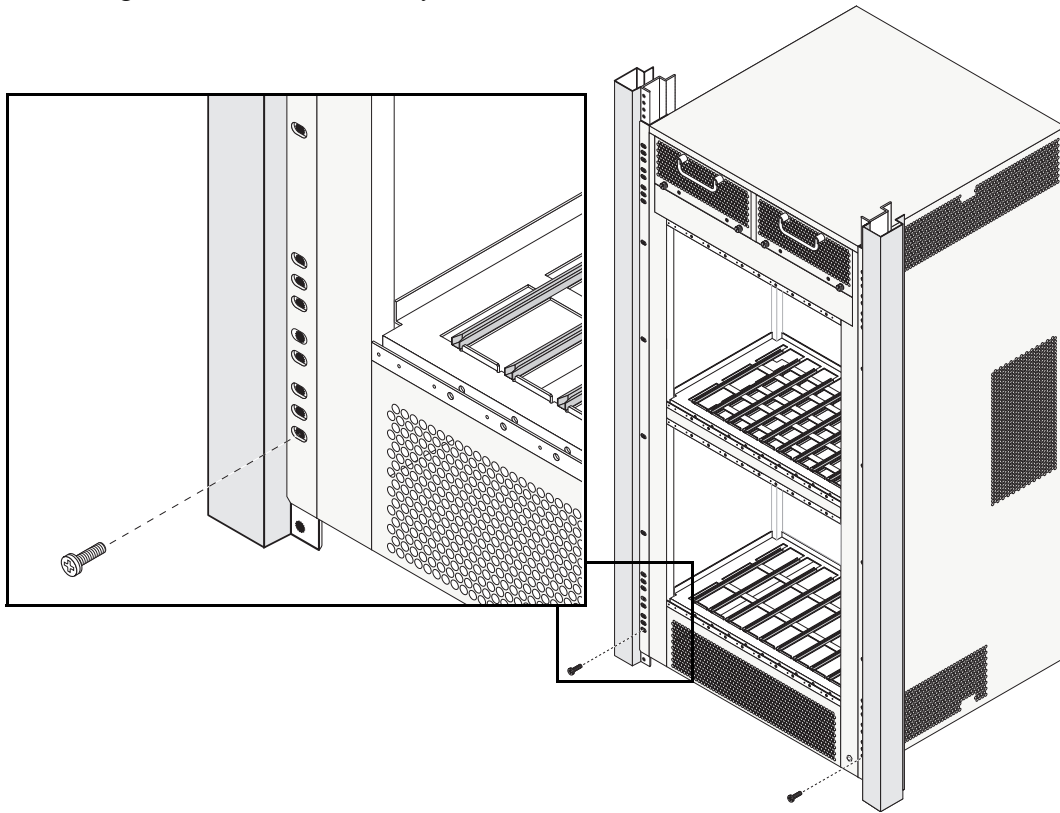

Installing Attachment Screws

Note. Be sure to install the screws in the *bottom hole* of each bracket, as shown, before proceeding.

- 7** Once the screws at the bottom of each bracket are secure, install the remaining screws. Be sure that all screws are securely tightened.

Stand-Alone

The OmniSwitch 8800 can be installed unmounted as a stand-alone unit. Be sure that the installation location is a stable, flat surface that can accommodate the *fully-populated* weight of all switches being installed. One fully-populated OmniSwitch 8800 weighs approximately 220 pounds (100 kilograms).

Note. OmniSwitch 8800 switches must be installed “right side up.” Never attempt to operate a switch while it is lying on its side.

To install the switch as a stand-alone unit, follow the steps below:

- 1** Use two or more people to move and position the unpopulated chassis upright on the floor or bench where it is to be installed.
- 2** Be sure that adequate clearance has been provided for chassis airflow and that you have placed the chassis within reach of all required AC outlets. For recommended airflow allowances, refer to [page 2-8](#).

Note. For detailed information on installing additional components and connecting the switch, refer to the *OmniSwitch 8800 Getting Started Guide*.

Power Supplies

The OmniSwitch 8800 supports a total of four power supplies (refer to [page 2-15](#) for important redundancy information). The OS8-PS-1375A power supplies are installed in the power supply bays located at the bottom of the rear side of the chassis. See [page 2-6](#) for a slot diagram showing the power supply bays.

TEMP FAIL (Top LED).

Off when the power supply is operating under supported temperature conditions.

Displays solid amber when a temperature error is detected in the power supply housing. If a temperature error is detected, check for an airflow obstruction at the air intake vent or at the back of the chassis. If no airflow obstruction exists, remove or replace the power supply immediately. Refer to the sections below for important information on replacing power supplies and power supply redundancy.

DC OK (Middle LED).

Displays solid green when the power supply's DC current status is OK and the power supply is operating. Off when the power supply is not operating.

AC OK (Bottom LED).

Displays solid green when the power supply's AC current status is OK and the power supply is operating. Off when the power supply is not operating.

Power Switch.

↑ indicates **on** position;
○ indicates **off** position.

Power Supply LEDs

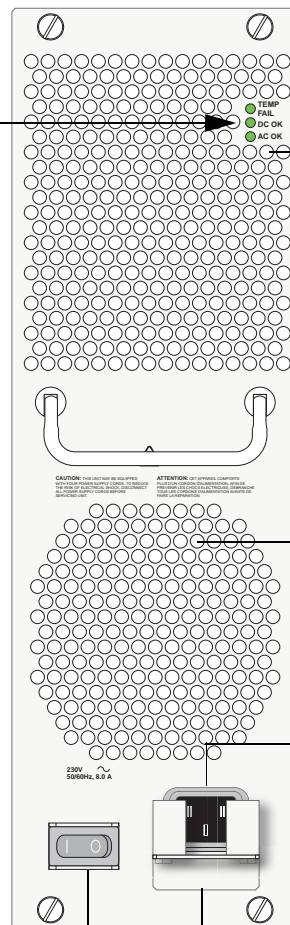

Air Exhaust Vent. The air exhaust vent provides cooling and temperature control for the power supply. Maintain a front clearance of at least six inches to ensure proper airflow.

For additional airflow information, refer to [page 2-35](#).

Air Intake Vent. The air intake vent provides cooling and temperature control for the power supply. Maintain a front clearance of at least six inches to ensure proper airflow.

For additional airflow information, refer to [page 2-35](#).

Power Connector Socket. Type IEC-320-C13.

It is recommended that you use Alcatel-provided power cords.

Note: You must use 220 Volt power receptacles and 220 Volt power cords.

Power Cord Retainer.

Alcatel provides a two-piece metal retainer with each power supply. This retainer is used to secure the power cord so that it cannot be accidentally pulled from the socket.

For information on using this retainer, refer to [page 2-20](#).

AC Power Supply Front Panel

OmniSwitch 8800 AC Power Supply Technical Specifications

Input Voltage	180–240 VAC
Frequency	50/60 Hz
Input Power (per supply)	1618 Watts
Input Power (per chassis)	4853 Watts
Output Power	60 Amps at 24 Volts (1375 Watts)

Warning. In North America, OmniSwitch 8800 power supplies require 220 Volt power cords connected to 220 Volt power receptacles. Do *not* use 110 Volt power cords or receptacles.

1375 Watt DC-to-DC Power Supply

In addition to AC power supplies, the OS8800 switch offers DC power support (OS8-PS-1375D). As with the AC power supplies, DC supplies are installed in the power supply bays located at the bottom-rear of the chassis. See [page 2-6](#) for a slot diagram showing the power supply bays.

TEMP FAIL (Top LED).
Off when the power supply is operating under supported temperature conditions.

Displays solid amber when a temperature error is detected in the power supply housing. If a temperature error is detected, check for an airflow obstruction at the air intake vent or at the back of the chassis. If no airflow obstruction exists, remove or replace the power supply immediately. Refer to the sections below for important information on replacing power supplies and power supply redundancy.

DC OUT OK (Middle LED).

Displays solid green when the power supply's DC *output* status is OK and the power supply is operating. Off when the power supply is not operating.

DC IN OK (Bottom LED).

Displays solid green when the power supply's DC *input* status is OK and the power supply is operating. Off when the power supply is not operating.

Power Switch.

⏻ indicates **on** position;
⏻ indicates **off** position.

Power Supply LEDs

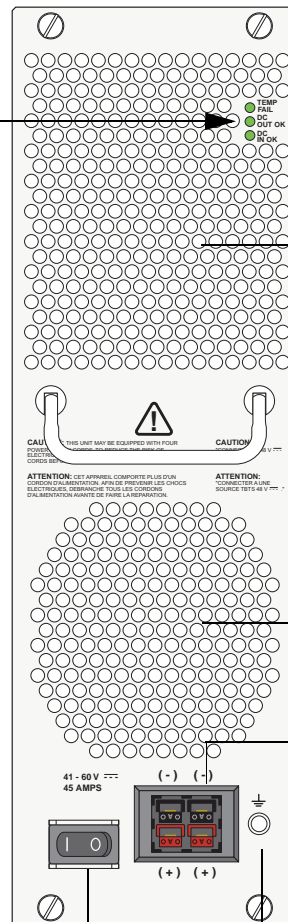

Air Exhaust Vent. The air exhaust vent provides cooling and temperature control for the power supply. Maintain a front clearance of at least six inches to ensure proper airflow.

For additional airflow information, refer to [page 2-35](#).

Air Intake Vent. The air intake vent provides cooling and temperature control for the power supply. Maintain a front clearance of at least six inches to ensure proper airflow.

For additional airflow information, refer to [page 2-35](#).

DC Power Connector Socket.

Anderson Powerpole modular connector, or equivalent. The connector socket ships factory-installed in the power supply's front panel. For information on the DC power connectors, including notes on connecting the power cable, refer to [page 2-16](#).

Safety Ground Connector.

A safety ground is provided on each power supply and is used to ground the OS8800 chassis.

For information on properly connecting the safety ground, refer to [page 2-26](#).

DC Power Supply Front Panel

OmniSwitch 8800 DC Power Supply Technical Specifications

Input Voltage	-48VDC to -60VDC
Ambient Temperature	0–70 degrees Celsius (operating) -40–85 degrees Celsius (non-operating)
Humidity	5%–95% relative humidity, non-condensing
Altitude	10,000 feet above sea level and 32 degrees Celsius ambient air temperature maximum (operating) 50,000 feet above sea level (non-operating)

DC Power Supply Connection

In the current release, a 15-inch pre-assembled cable harness is shipped with each DC-to-DC power supply. You can plug this cable harness directly into the DC power connector on the power supply. Refer to the important information below before connecting a DC power supply.

Connecting the DC Cable Harness to the Chassis Power Supply

When plugging in the cable, insert the connector end of the cable harness into the power supply connector until it clicks firmly into place. This is an indication that the connector is secure and properly seated.

Connecting the DC Cable Harness to the DC Power Source

The other end of the cable harness is bare. Users must assemble and connect this end to the DC power source or to a cable coming from the power source. In addition to following the important guidelines listed below, be sure to consult specifications for the DC power source more information.

- Connect the power supply to a reliably grounded 48VDC SELV source.
- The branch circuit overcurrent protection must be rated 30A.
- Use 10AWG copper conductors.
- A readily accessible disconnect device that is suitably approved and rated shall be incorporated in the field wiring.
- The power supply shall be installed in a restricted access location.
- The power supply shall used with an Anderson Power Products model 1460G1 cord connector body.

Power Supply Redundancy

While the switch is running, all power supplies installed and operating share the electrical load. If a power supply is physically removed from the chassis or fails unexpectedly, the remaining power supplies automatically take up the load without disrupting the switch. However, for this failover to work, you must have at least one redundant power supply installed and running in your switch at all times.

Redundancy Defined

Power supply redundancy is defined as having at least one power supply more than the minimum switch requirement (N+1). The minimum switch requirement is based on the number of CMM, SFM, and NI modules installed. The OmniSwitch 8800 supports up to a maximum of four power supplies per chassis. Three power supplies will provide N+1 resiliency to support configuration with up to eight NIs installed; four power supplies will provide N+1 resiliency for configuration with more than eight NIs installed.

Monitoring Power Supply Status. To check the number of power supplies currently operating, and the status of each power supply, use the **show power** command. For example:

```
-> show power supply 1
Module in slot PS-1
  Model Name:           OS8-PS-1375A,
  Description:         OS8-PS-1375A,
  Part Number:         901978-10,
  Hardware Revision:   ,
  Serial Number:       B42N101P2,
  Manufacture Date:    OCT 18 2002,
  Firmware Version:    ,
  Admin Status:        POWER ON,
  Operational Status:  UP
  Power Provision      1375
```

For more information about these displays, see the “Chassis Management and Monitoring Commands” chapter in the *OmniSwitch CLI Reference Guide*.

Adding a Power Supply

You can add a power supply to the chassis at any time without disturbing the switch’s network functions. You are not required to power down the switch to add a power supply.

Hot Swapping a Power Supply

Hot swapping a power supply refers to the action of *replacing* a power supply while the switch is operating. To hot swap a power supply without disrupting switch operations, you must first have power supply redundancy (N+1). Otherwise, switch operations may be disrupted.

Permanently Removing a Power Supply

If you plan to permanently remove a power supply while the switch is operating, verify that you have effective power supply redundancy before doing so. Otherwise, switch operations may be disrupted.

Additional Information. For instructions on installing and removing power supplies, refer to pages [2-19](#) through [2-22](#). For important information on power supply redundancy, refer to [page 2-15](#).

Installing a Power Supply

- 1** If there is a blank cover panel over the power supply bay, loosen the four captive screws located at the four corners of the blank cover panel. If necessary, use a flat-blade screwdriver to loosen the screws. Set the blank cover panel aside.
- 2** Be sure that you do not attempt to install the power supply upside down. When orienting the power supply, note that the on/off switch and power cord socket are located at the *bottom* of the power supply.
- 3** With one hand, grasp the handle at the front of the power supply. Place your other hand under the power supply casing to support its weight.
- 4** Carefully insert the rear of the casing into the power supply bay and slide the power supply back until its connector meets the chassis backplane connector.

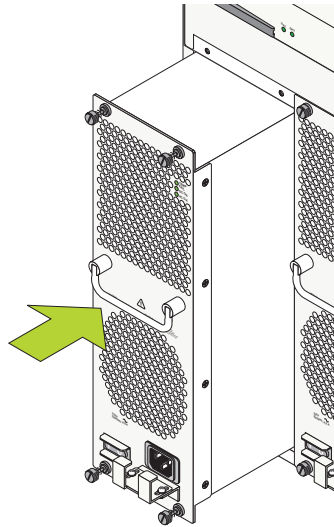

- 5** Continue sliding the power supply back until the front panel meets the front of the chassis. *Do not force the power supply into the bay. Otherwise you can damage the connectors.*
- 6** Tighten the four captive screws, located at the four corners of the power supply's front panel. *Be sure not to overtighten the captive screws. If you use a screwdriver, the torque used to tighten the screws must not exceed 2.3 inch pounds.*

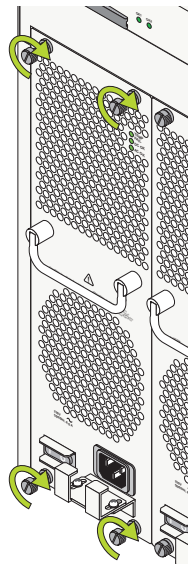

- 7** Verify that the power supply's on/off switch is in the off (O) position.
- 8** If no power is attached proceed to Step 9; otherwise proceed to Step 11.
- 9** Remove the two screws on the top of power cord retainer with a Phillips-head screwdriver. Do not discard these screws; you will need to reinstall them later.

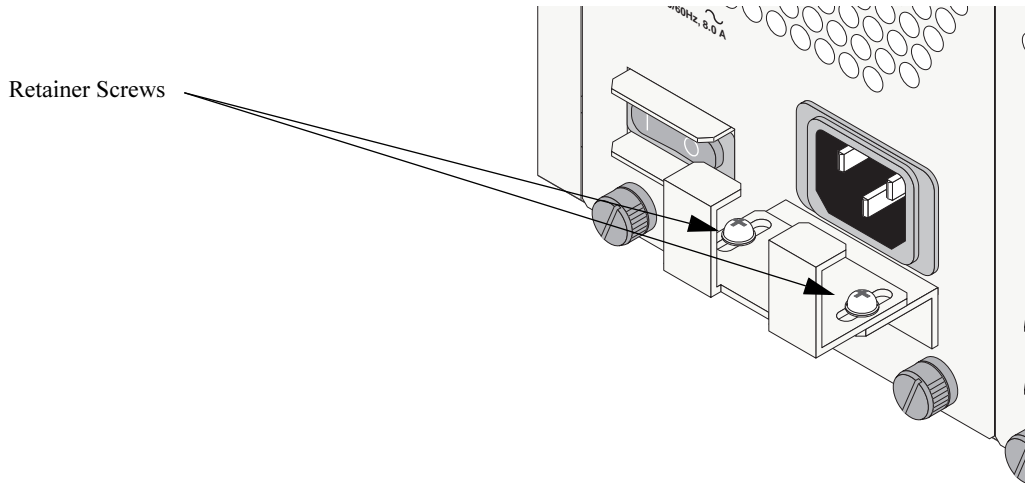

- 10** Slide the end of the power cord through the top portion of the retainer until it stops.

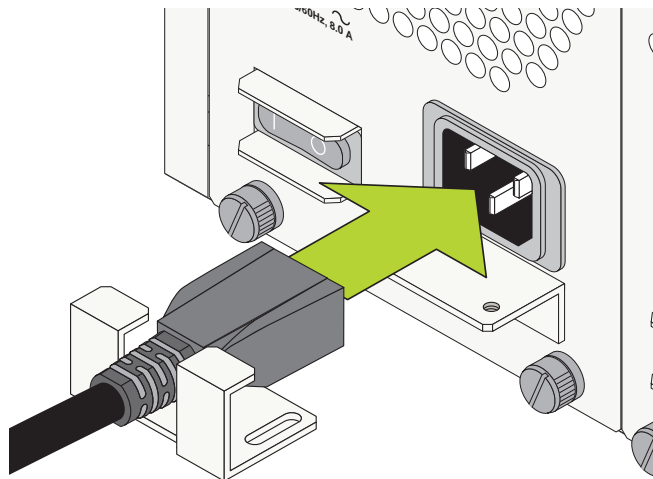

- 11** Plug the power cord into the power supply's socket. Make sure that the power cord is attached securely to the outlet.

Note. The power cord must be Pluggable Type B, minimum 16AWG.

12 Use a Phillips-head screwdriver to attach the top portion of the retainer to the bottom portion with the two Phillips-head screws.

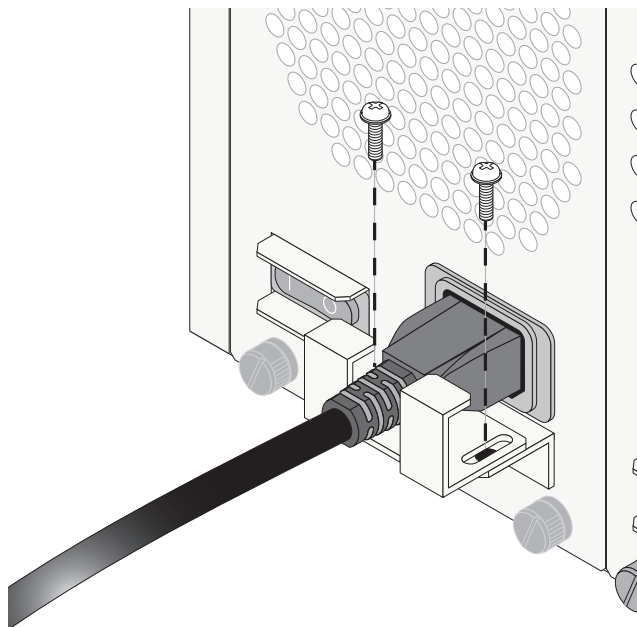

13 Once the power cord is secured in the retainer, plug the other end of the power cord into an easily-accessible, *properly grounded* outlet. *Do not use an extension cord.*

Removing a Power Supply

- 1** Before removing a power supply, make sure that the power switch is in the off (O) position. Unplug the power cord from the AC socket, as well as from the socket on the power supply's front panel.
- 2** If you wish to remove the power cord proceed to Step 3; otherwise proceed to Step 5.
- 3** Remove the two screws on the top of retainer with a Phillips-head screwdriver. Do not discard these screws; you will need to reinstall them later.

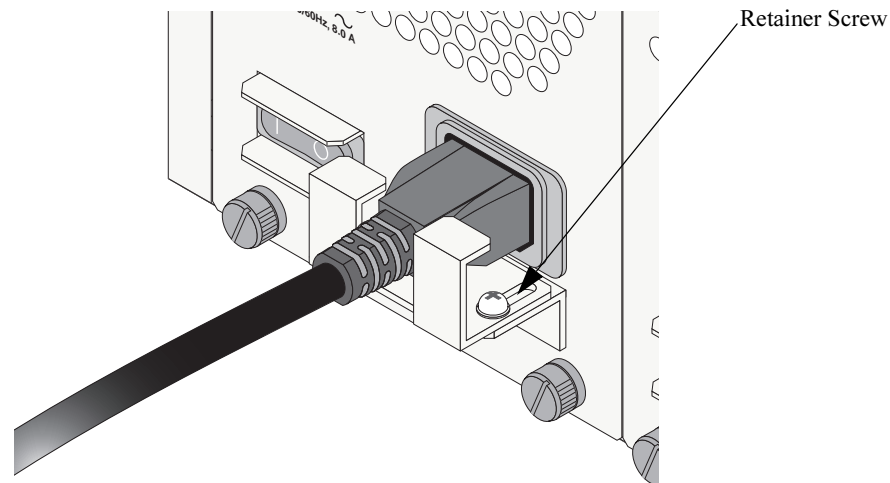

- 4** Remove the top part of the metal retainer and place it in a safe location.
- 5** Loosen the four captive screws, located at the four corners of the power supply's front panel. If necessary, use a flat-blade screwdriver to loosen the screws.

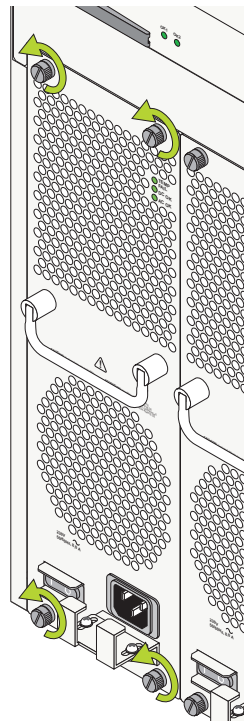

6 With one hand, grasp the handle at the front of the power supply and slowly pull the power supply out of the power supply bay. *Do not pull the power supply completely out of the bay with one hand.*

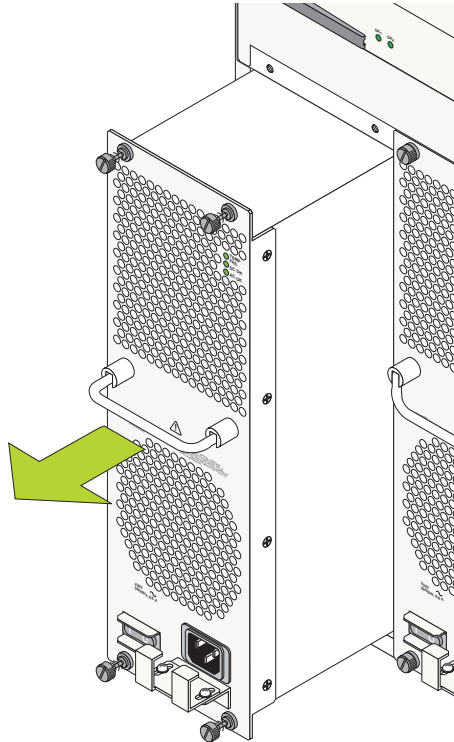

7 When the power supply is pulled out far enough (about 10 inches), place your other hand under the power supply casing to support its weight.

8 Continue pulling the power supply out until it is removed from the chassis.

9 If you are not replacing the power supply, be sure to install a blank cover panel over the empty power supply bay. To install a blank cover panel, place it over the empty power supply bay and align the panel's four captive screws with the threaded holes in the chassis. Once the screws are aligned, fasten the blank cover panel to the chassis.

Power Cords

Because the power cord is the power supply's main disconnect device, it should be plugged into an easily accessible outlet. In the event that your power cord is lost or damaged, refer to the specifications below.

Warning. There is a possible hazard where a fuse is used in the neutral of single-phase equipment either permanently connected or provided with a non-reversible plug.

Specifications

The power cord must be Pluggable Type B, minimum 16AWG. One end terminates in an IEC-320-C13 attachment plug (female) and the other end (male) terminates as required by the country where it will be installed.

European cords must be Harmonized (HAR) type. Refer to the information below for power plug types by region:

Country or Region	Power Cord Types
Bahamas, Barbados, Belize, Brazil, Canada, Cayman Islands, Costa Rica, Dominican Republic, Ecuador, El Salvador, Guam, Guatemala, Haiti, Honduras, Jamaica, Japan, Laos, Mexico, Nicaragua, Marianas Islands, Panama, Peru, Philippines, Puerto Rico, Saudi Arabia, St. Pierre, Thailand, Taiwan, United States, Venezuela, Virgin Islands	Twist-lock NEMA 16/20
Continental Europe (except Italy)	CEE 7/7 (Schuko)
United Kingdom and Ireland	BS 1263
Australia and New Zealand	AS 3112
Italy	CEI 23-16/VII (16 Amps)

Attention. Do not use standard 18-gauge (18/3) cords such as those supplied with personal computers.

DC-to-DC Power Cords

For DC-to-DC connections, refer to [page 2-16](#) for additional guidelines and information.

Redundant AC Circuit Recommendation

It is recommended that each AC outlet resides on a separate circuit. With redundant AC, if a single circuit fails, the switch's remaining power supplies (on separate circuits) will likely be unaffected and can therefore continue operating.

Note. The switch must have power supply redundancy for the redundant AC circuit to be effective. Refer to “1375 Watt DC-to-DC Power Supply” on page 2-15 for more information.

The diagram below shows a simple redundant AC circuit scenario.

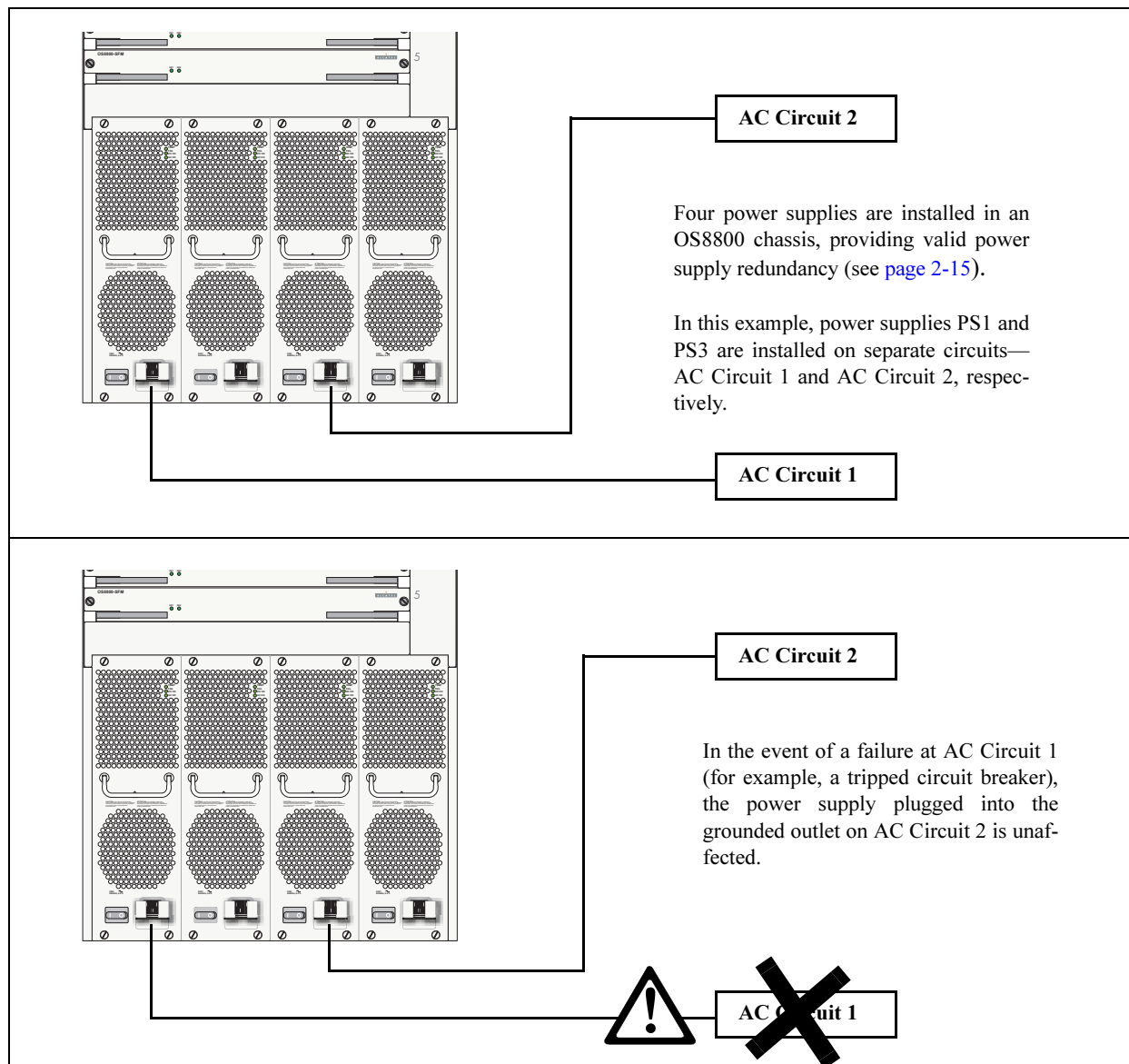

Redundant AC Circuit Example

Grounding the Chassis

The switch has two threaded holes for grounding screws located on the back of the chassis, just above the rear (fabric) fan tray. These holes use 10-32 screws and are approximately one inch apart. These holes are surrounded by a small paint-free rectangular area, which provides metal-to-metal contact for a ground connection.

Use this connector to supplement the ground provided by the AC power cord. To do so, install a Panduit Grounding Lug (type LCD8-10A-L) using 8AWG copper conductors to the paint-free rectangular area. Be sure to use a crimping tool.

Temperature Management

The operating temperature of your switch is an important factor in its overall operability. In order to avoid a temperature-related system failure, your switch must always run at an ambient temperature between 0 and 45 degrees Celsius (32 to 113 degrees Fahrenheit).

To avoid chassis over-temperature conditions, follow these important guidelines:

- 1** Be sure that your switch is installed in a well-ventilated environment. To ensure adequate airflow, allow at least six inches of clearance at the front and back of the chassis. In addition, leave at least two inches of clearance at the left and right sides.
- 2** If your switch chassis is not fully populated with NI modules, be sure that blank cover panels are installed at empty slot positions at all times. Blank cover panels help regulate airflow and thus regulate the overall operating temperature in the switch. Refer to [page 2-37](#) for more information.

Monitoring Chassis Temperature Status. To check the switch's current temperature status, use the [show temperature](#) command. For example:

```
-> show temperature
Hardware Fabric Temperature (deg C)           = 34,
Hardware Cpu Temperature (deg C)              = 28,
Temperature Fabric Upper Threshold Range (deg C) = 60 to 75,
Temperature Cpu Upper Threshold Range (deg C)  = 50 to 62,
Temperature Fabric Upper Threshold (deg C)     = 60,
Temperature Cpu Upper Threshold (deg C)       = 50,
Temperature Range                             = UNDER THRESHOLD,
Temperature Fabric Danger Threshold (deg C)    = 75,
Temperature CPU Danger Threshold (deg C)      = 62
```

For more information about these displays, see the “Chassis Management and Monitoring Commands” chapter in the *OmniSwitch CLI Reference Guide*.

Temperature Errors

The CMM monitors the chassis ambient air temperature at all times via an onboard sensor. If an over-temperature condition occurs, there are two different levels of error severity:

- Warning threshold has been exceeded
- Danger threshold has been exceeded

Warning Threshold

If the temperature exceeds the switch's user-configurable *warning threshold*, the CMM sends out a trap. Traps are printed to the console in the form of text error messages. The CMM's TEMP FAIL LED also displays amber, indicating an error. (Refer to [Chapter 2, "Chassis and Power Supplies"](#) for CMM front panel descriptions, including status LEDs.)

When the warning threshold has been exceeded, switch operations remain active. However, it is recommended that immediate steps be taken to address the over-temperature condition.

Addressing warning threshold temperature conditions may include:

- Checking for a chassis air flow obstruction
- Checking the ambient room temperature
- Checking the fan tray status using the **show fan** command. See [page 2-30](#) for more information.
- Verifying that the warning threshold has not been manually set to an otherwise common or acceptable ambient temperature—for example, 31 degrees Centigrade. (The default warning threshold is 60C. This value may be configured using the **temp-threshold** command. The current set warning threshold may be viewed using the **show temperature** command.)

Note. Once the ambient air temperature is reduced to below the warning threshold, the CMM's TEMP FAIL LED automatically resets to green.

Danger Threshold

If the chassis ambient air temperature rises above the switch's danger threshold of 80 degrees Centigrade, the switch will power off all Network Interface (NI) modules until the temperature conditions have been addressed and the switch is manually booted. The danger threshold is factory-set and cannot be configured by the user.

Addressing danger threshold temperature conditions may include:

- Checking for a chassis air flow obstruction
- Checking the ambient room temperature
- Checking the fan tray status using the **show fan** command. See [page 2-30](#) for more information.

Chassis Fan Trays

The switch houses three fan trays—two bays located at the top of the front side of the chassis and one bay located at the middle of the back side of the chassis. The two front (chassis) fan trays, each consisting of two independently-operating fans, are the main temperature control component of the switch. These fan trays provide cooling airflow for all NI modules and CMMs. This airflow is a crucial factor in the switch's overall operability.

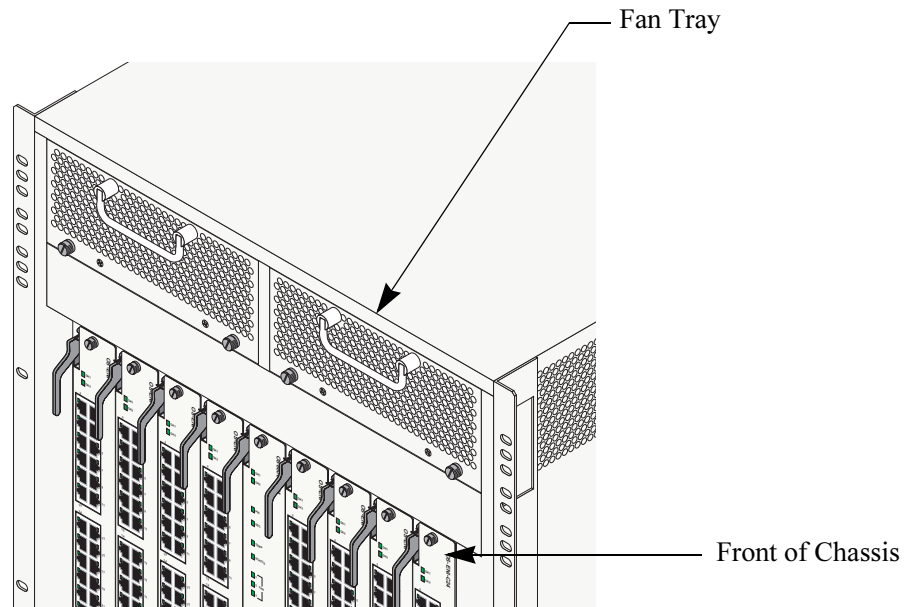

Chassis (Front) Fan Tray Location

Fan Tray Technical Specifications

Power for the fabric (back) and both chassis (front) fan trays 386 Watts (maximum)

Important. The chassis fan trays are a required component. Never attempt to operate the switch without these fan trays installed.

The back (fabric) fan tray consists of three independently-operating fans. The fan tray provides cooling airflow for all Switch Fabric Modules (SFMs). This airflow is a crucial factor in the switch's overall operability. Refer to [“Chassis Airflow” on page 2-35](#) for an overview of chassis airflow. Also, refer to [page 2-8](#) for important airflow considerations.

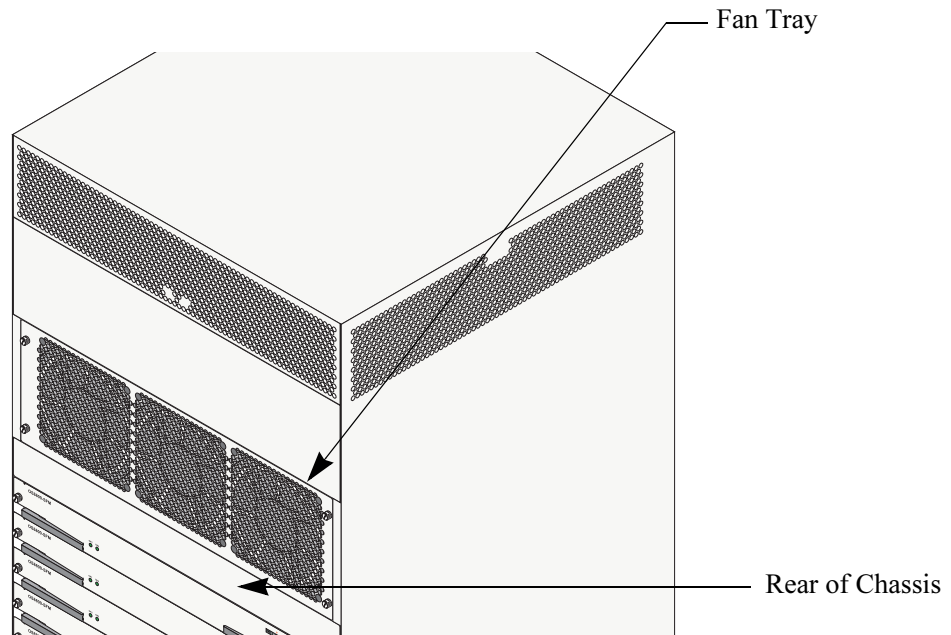

Fabric (Back) Fan Tray Location

Important. The fabric fan tray is a required component. Never attempt to operate the switch without this fan tray installed. (However, the loss of one of the three fans in the tray will not prevent switch operation.)

Monitoring Fan Tray Status

The CMM constantly monitors fan operation. If any of the switch's fan trays or any of the fans in a fan tray unexpectedly shuts down, the CMM sends out a trap and the appropriate fan tray LED (e.g., FAN 1, FAN 2, FAN 3) on the CMM's front panel shows amber.

Note. To check the switch's current fan tray status, use the **show fan** command. For example:

```
-> show fan
Fan           Status
-----+-----
Fan-1        Running
Fan-2        Running
Fan-3        Running
Fan-4        Running
Fan-5        Running
Fan-6        Running
Fan-7        Running
```

Fan-1 and Fan-2 are the fans in the left-hand chassis fan tray; Fan-3 and Fan-4 are the fans in the right-hand chassis fan tray; and Fan-5, Fan-6, and Fan-7 are the fans in the fabric fan tray. For more information about these displays, see the "Chassis Management and Monitoring Commands" chapter in the *OmniSwitch CLI Reference Guide*.

Fan Redundancy

In the event that *one* fan quits in either front (chassis) fan tray, the remaining fan will continue running; switch operations are not disrupted. (A warning message will be sent every five minutes.) However, if both fans in one front fan tray quits unexpectedly, then you must replace the fan tray within 1 minute before the switch begins to overheat and begin the power-down cycle.

In addition, in the event one fan in the front (chassis) tray and one fan in the rear (fabric) tray fails or two fans in the rear tray fail all Network Interface (NI) modules will shut down in 60 seconds.

In the event that one or two fans in the rear (fabric) fan tray quits unexpectedly, the remaining fans will continue running; switch operations are not disrupted. (A warning message will be sent every five minutes.) However, if all three fans in this fan tray quits unexpectedly then you must replace this fan tray within 2 minutes before the switch begins to overheat and begin the power-down cycle.

Note. For information on emergency replacement of the fan tray, refer to "[Hot Swapping a Fan Tray](#)" on [page 2-31](#).

Storing Backup Fan Trays. It is a good idea to keep at least one backup chassis (front) fan tray and at least one backup fabric (back) fan tray in your data facility or other hardware storage area.

Hot Swapping a Fan Tray

As stated previously, the fan trays are the main temperature control component of the switch. As a result, *a fan tray should never be removed while the switch is operating unless it is absolutely necessary.*

However, if a fan tray requires immediate replacement or service, the fan tray can be hot swapped—i.e., it can be changed out without shutting off the switch.

Important. Hot swapping a fan tray is a time-sensitive procedure. *If the fan tray is removed, it must be replaced within approximately five minutes* (in most cases). Otherwise, overheating will occur, which can lead to system failure.

For instructions on properly removing and installing a front fan tray, refer to [“Removing a Front Fan Tray” on page 2-31](#) and [“Installing a New Front Fan Tray” on page 2-32](#). For instructions on properly removing and installing a rear fan tray, refer to pages [“Installing a New Front Fan Tray” on page 2-32](#) and [“Installing the New Back Fan Tray” on page 2-34](#).

Removing a Front Fan Tray

- 1 Begin by turning both locking levers (latches) one-quarter turn counterclockwise.

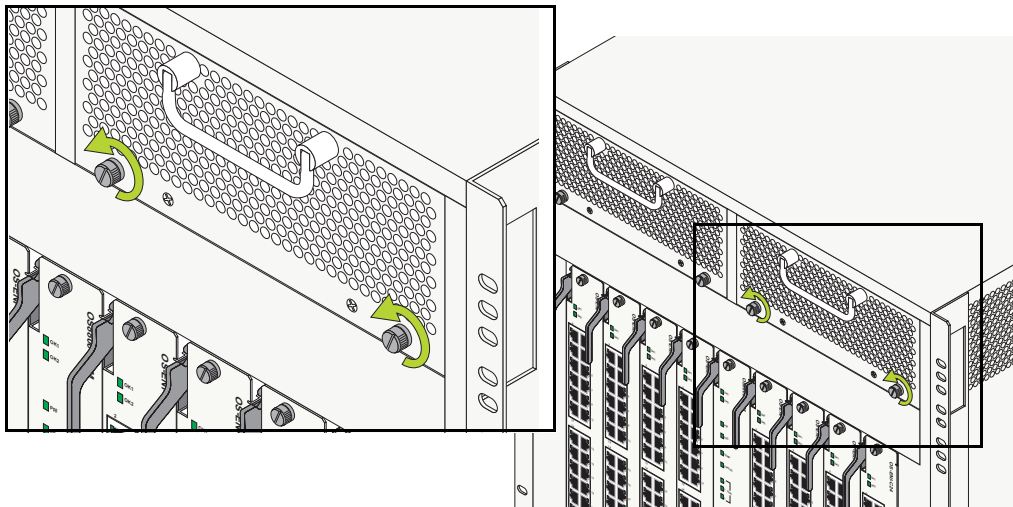

- 2 Pull the fan tray straight out and away from the switch.

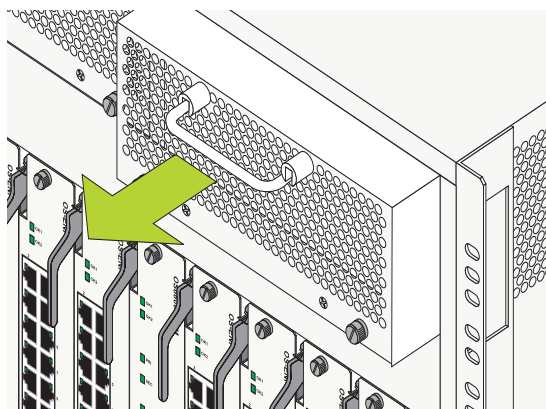

Installing a New Front Fan Tray

- 1 Push the fan tray straight against the switch chassis.

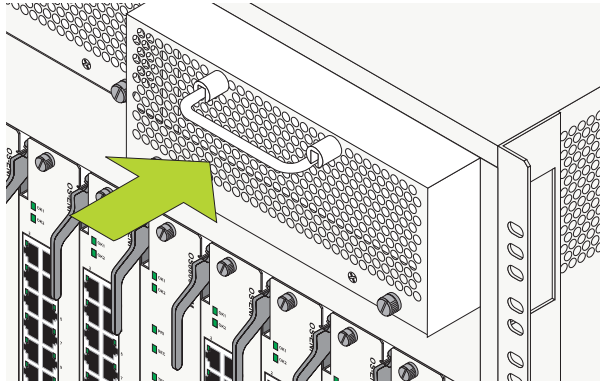

- 2 When the attachment brackets are flush against the chassis' rear panel, turn the two locking levers (latches) clockwise one-quarter turn.

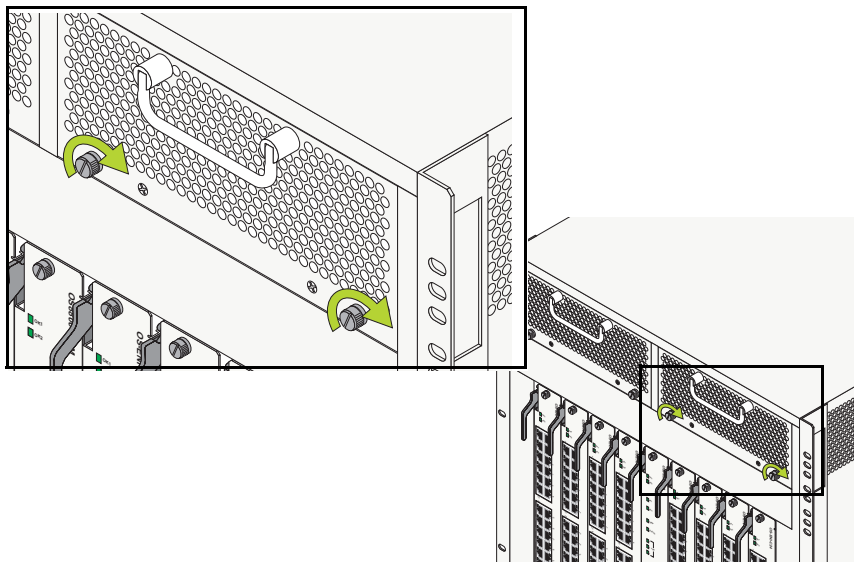

Removing the Back Fan Tray

1 Begin by loosening the four captive screws located at the four corners of the fan tray. Use a flat-head screwdriver if necessary.

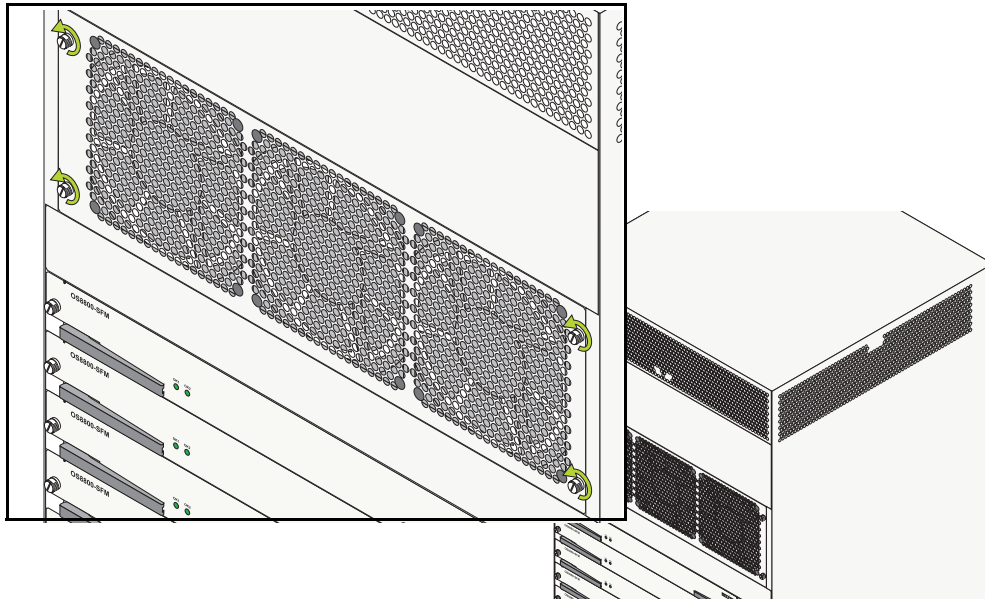

2 After the captive screws have been loosened (i.e., disengaged from the threaded holes in the chassis), pull the fan tray straight out and away from the switch.

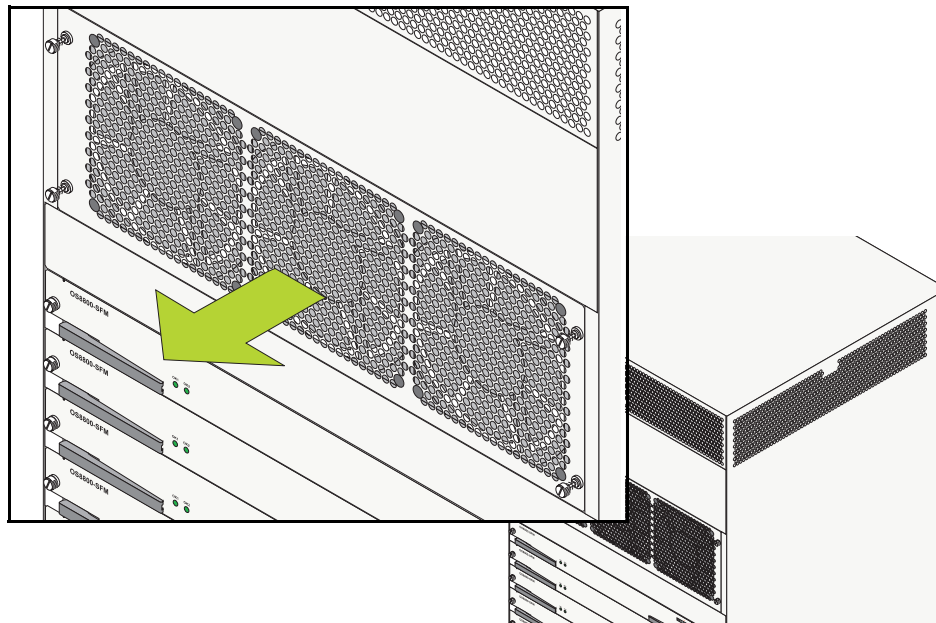

Installing the New Back Fan Tray

- 1 Align the new fan tray's captive screws with the threaded holes at the rear of the chassis. The fan tray has an onboard power connector that plugs into a power connector socket on the chassis. In addition to aligning the captive screws, be sure that this power connector is aligned with the power connector socket on the chassis.
- 2 Next, push the fan tray straight against the switch chassis.

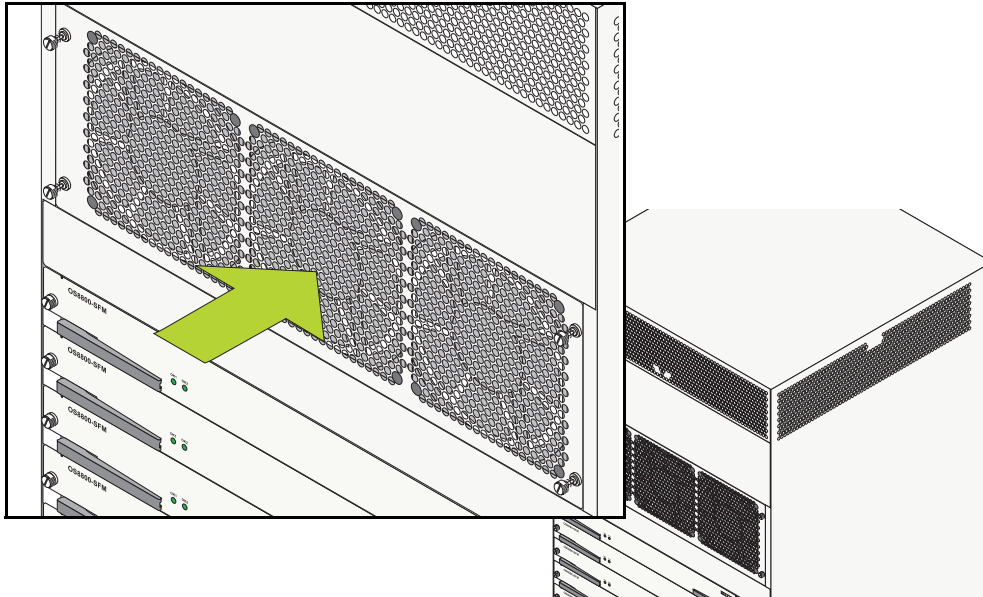

- 3 When the attachment brackets are flush against the chassis' rear panel, tighten the captive screws. *Be sure not to overtighten the captive screws. If you use a screwdriver, the torque used to tighten the screws must not exceed 2.3 inch pounds.*

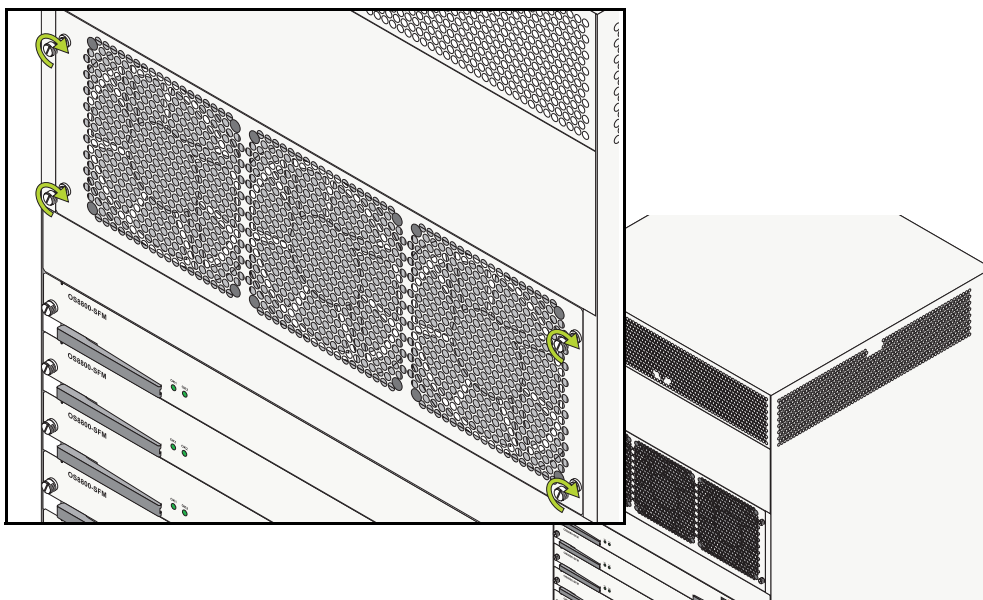

Chassis Airflow

The chassis (front) fan trays pull air from the air intake vents located at the bottom-left, bottom-front, and bottom-right sides of the chassis. The air is directed vertically through the chassis' front module compartment and past the NI and CMM circuit boards. Airflow is then exhausted through the fan trays at the top-left, top-front, top-right, and top-back sides of the chassis.

The fabric (back) fan tray pulls air from the air intake vents located at the middle-right side of the chassis. The air is directed horizontally over the SFM circuit boards. Airflow is then exhausted through the fan tray at the back of the chassis, just below the exhaust vents of the chassis fan trays.

Important. Maintain a clearance of at least six inches at the front and back of the chassis as well at least two inches at the left and right sides. Otherwise, airflow may become restricted. Restricted airflow can cause your switch to overheat; overheating can lead to switch failure.

The figures below provide illustrated airflow diagrams for OS8800 switches. See the figures below for an airflow diagram. See [page 2-37](#) for an airflow diagram describing the chassis' power supply bays.

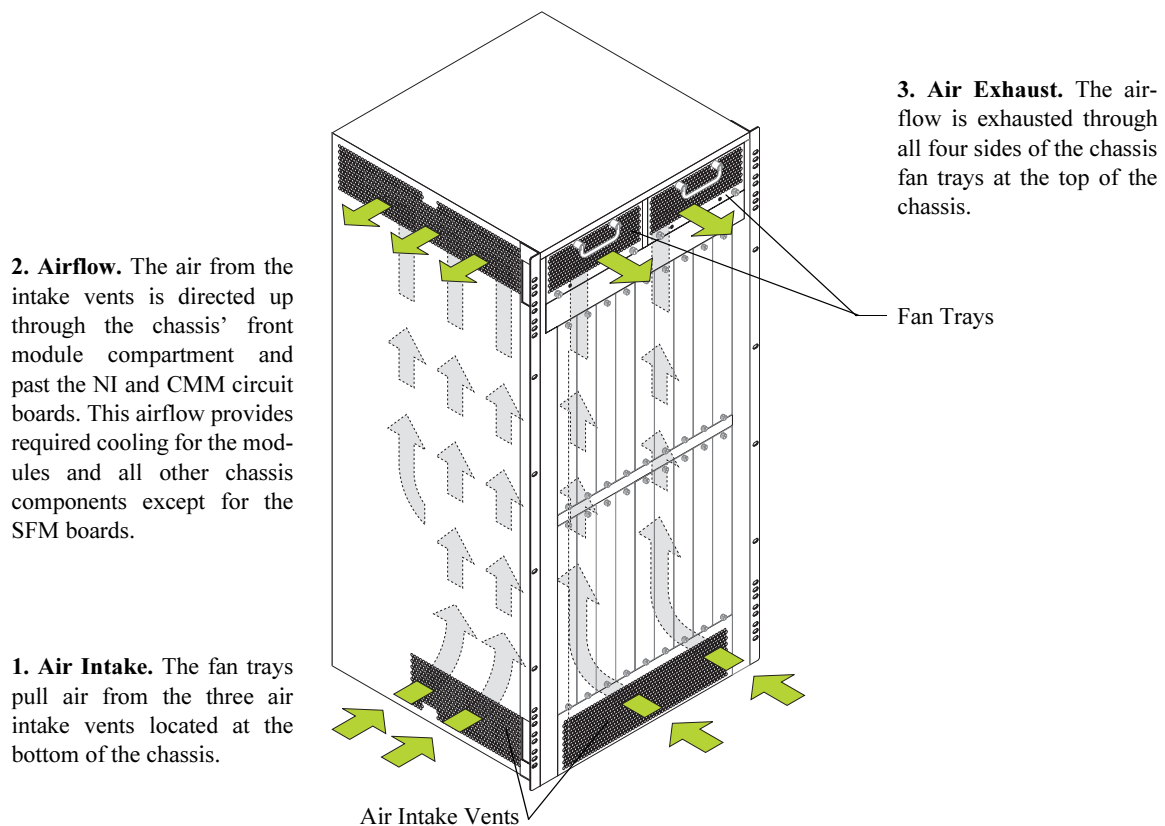

Chassis (Front) Airflow for OS8800 Switches

2. Airflow. The air from the intake vents is directed horizontally over the SFM circuit boards.

1. Air Intake. The fan tray pulls air from the middle-right side of the chassis.

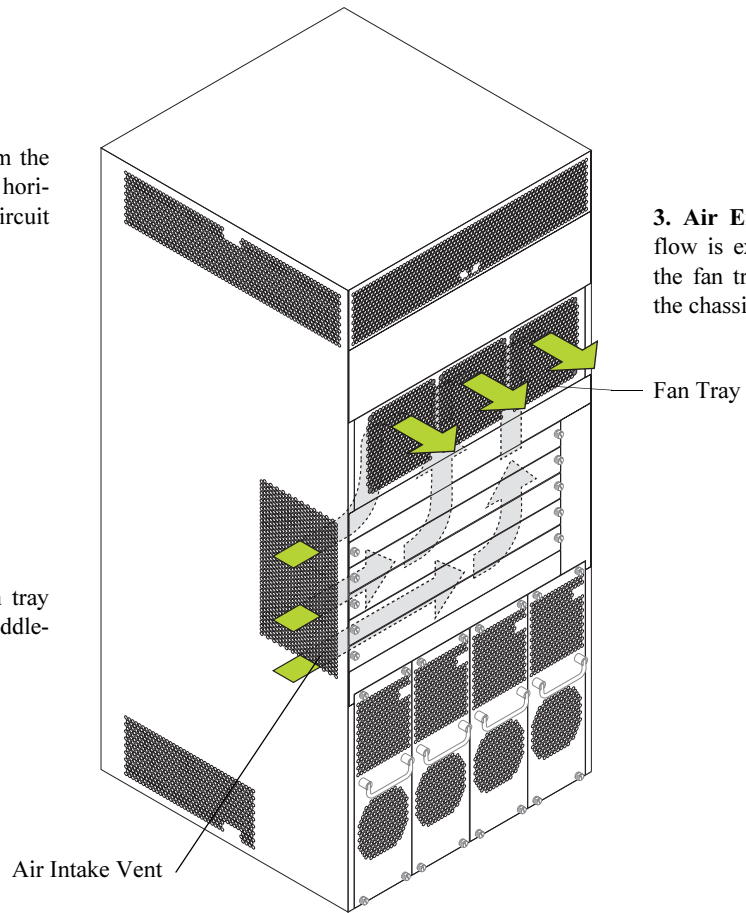

3. Air Exhaust. The air flow is exhausted through the fan tray at the rear of the chassis.

Chassis (Back) Airflow for OS8800 Switches

Power Supply Fans

The chassis fan tray does not regulate power supply temperature. Instead, a cooling fan is installed in each power supply. Because power supply bays are self-contained, each fan operates independently, cooling only its associated power supply. Refer to the diagram below for more information.

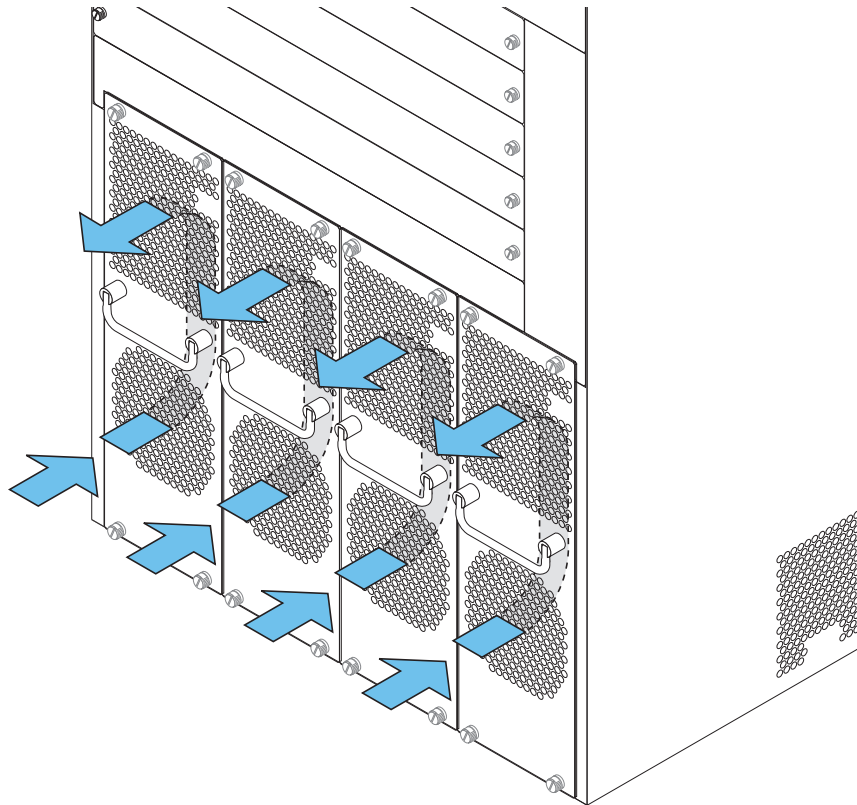

1. Air Intake. The fan unit, located behind each power supply front panel, pulls air from the air intake vents on the bottom of the power supply.

2. Airflow. The air from the intake vent is directed through the vents at the bottom power supply and over the power supply's internal components.

3. Air Exhaust. Airflow is exhausted through the vents located at the top of the power supply.

Airflow for Power Supplies

See [page 2-13](#) for detailed power supply front panel and LED information.

Blank Cover Panels and Chassis Airflow

Blank cover panels are provided with your switch and are used to cover empty CMM, SFM, and NI slots, as well as empty power supply bays. These cover panels play an important role in chassis airflow and temperature management. If your switch is not fully populated and blank cover panels are *not installed* over empty slot locations, airflow is affected.

For example, if NI and/or CMM blank cover panels are missing, air does not take the direct route from the air intake vents, up through the chassis front module compartment, and out through the fan trays. Instead, a portion of the airflow is allowed to be drawn in through the front module compartment of the chassis. As a result, normal airflow is disrupted and an extra task is placed on the fan tray to cool the chassis. Refer to the figure below for more information.

Cover panels also provide protection for module processor boards and other sensitive internal switch components by closing off a chassis that is not fully populated.

Note. Because they regulate airflow and help protect internal chassis components, blank cover panels should be installed over empty module slots and power supply bays at all times.

Missing Cover Panels.

Missing cover panels affect airflow by allowing air to be drawn in through the front module compartment of the chassis. As a result, the direct route from the air intake vents to the fan tray exhaust is disrupted.

For optimal airflow and chassis component protection, always install blank cover panels over empty module slots and power supply bays.

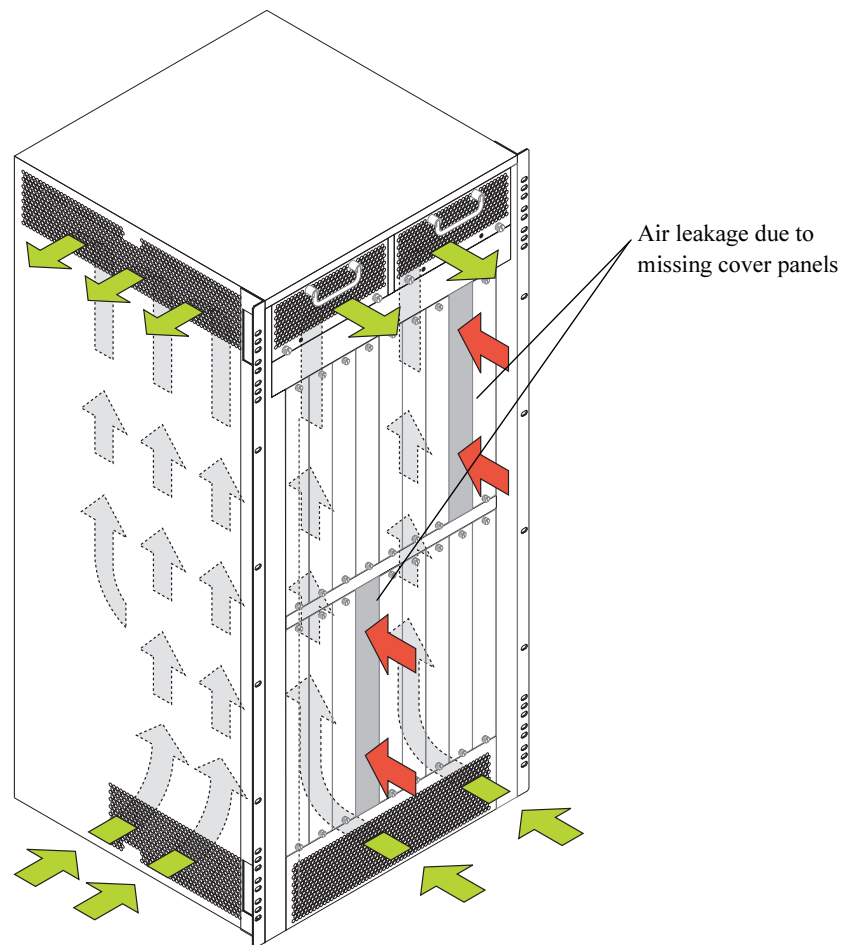

Effects of Missing Blank Panels on Chassis Airflow

Managing MAC Addresses on the Switch

Your OmniSwitch 8800 is shipped with thirty-two (32) factory-installed MAC addresses. These MAC addresses, which are stored on an EEPROM card in the chassis, are used by the switch as unique identifiers for the following functions:

- Base chassis MAC address
- Ethernet Management Port (EMP)
- 802.1X authentication
- VLAN router ports

Similar to IP addresses, MAC addresses are assigned by the Internet Assigned Numbers Authority (IANA) and distributed to users in sequential blocks. A sequential block of MAC addresses is referred to as a MAC address *range*.

The switch's EEPROM contains one factory-installed MAC address range. As mentioned above, this default range contains 32 MAC addresses. The first—or *start*—MAC address in this range is always allocated as the base chassis MAC address. The last—or *end*—MAC address is always allocated for the Ethernet Management Port (EMP). The *second* MAC address is allocated for 802.1X authentication.

For information on VLAN router ports and MAC address allocation, refer to [page 2-41](#).

MAC Range Guidelines

- Because MAC range 1 contains addresses that are automatically allocated for switch functions (base chassis, 802.1X, and EMP), you cannot delete this range at any time.
- The factory-installed 32 MAC addresses are sufficient for most network configurations. However, if you require additional MAC addresses for your network, you may purchase additional MAC addresses from Alcatel. Contact your Alcatel representative for more information.

OS8800 MAC Range Specifications

Number of factory-installed MAC ranges	1
Maximum MAC ranges allowed on the switch	1
Default number of MAC addresses in MAC range 1	32
Maximum MAC addresses allowed in MAC range 1	256
Base chassis MAC address	Unique to each switch. The base chassis MAC address is always the <i>first</i> MAC address listed in MAC range 1.
802.1X MAC address	Unique to each switch. The <i>second</i> MAC address in the range is always allocated for 802.1X authentication.
Ethernet Management Port (EMP) MAC address	Unique to each switch. The EMP MAC address is always the <i>last</i> MAC address listed in MAC range 1.
VLAN Router Port MAC addresses	Unique to each switch. In multiple MAC router mode, each VLAN router port is assigned a unique MAC address. These unique addresses are allocated from the remaining 29 MAC addresses in the range (index numbers 3 through 31). In single MAC router mode, all VLAN router ports use the base chassis MAC address. For more information on VLAN router ports and MAC address allocation, refer to page 2-41 .
MAC router modes supported	Multiple and single
Default MAC router mode	Multiple

VLAN Router Ports and MAC Address Allocation

The sections below cover MAC address allocation for all new VLAN router ports configured on the switch. MAC address allocation is dictated by the type of MAC router mode that is currently operational on the switch. The two MAC router modes are *multiple MAC router mode* and *single MAC router mode*.

Note. Regardless of which MAC router mode is operating, the switch's default VLAN 1 always uses the base chassis MAC address. Also, each VLAN can be assigned two concurrent router port types, IP and IPX. If both router port types are assigned to a VLAN, they will share the same MAC address.

Multiple MAC Router Mode

By default, each VLAN router port is assigned a unique MAC address. This default function is referred to as *multiple MAC router mode*. Multiple MAC router mode provides important compatibility with Alcatel's Omni Switch/Router (OmniS/R) products. If you have OmniS/R products in your network and are using VLAN router ports on your switch, multiple MAC router mode should remain enabled.

In multiple MAC router mode, MAC addresses are allocated sequentially from EEPROM, starting from the *third* address in the default range.

Reminder. The first, second, and last MAC addresses are allocated to the chassis, 802.1X, and the EMP, respectively. This leaves a total of 29 MAC addresses (MAC range index numbers 3 through 31) available to VLAN router ports.

Enabling Single MAC Router Mode

When multiple MAC router mode is disabled, all VLAN router ports configured on the switch use the base chassis MAC address as an identifier. This is also referred to as *single MAC router mode*.

Single MAC router mode helps preserve MAC addresses on the switch. However, this non-default function does not provide important compatibility with Alcatel's Omni Switch/Router (OmniS/R) products.

You cannot enable single MAC router mode via the CLI. To enable single MAC router mode, you must add the following command syntax to the **boot.cfg** file:

```
vlan router mac multiple disable
```

After adding the command syntax to the **boot.cfg** file and saving your changes, reboot the switch.

When the switch boots, the system software reads from the **boot.cfg** file. All valid command syntax, including **vlan router mac multiple disable**, is initialized and single MAC router mode is enabled. Because the syntax has been added to the switch's **boot.cfg** file, single MAC router mode will remain enabled after subsequent switch reboots.

Returning to Multiple MAC Router Mode

You cannot re-enable multiple MAC router mode via the CLI. In order to return the switch to this default setting, you must add the following command syntax to the **boot.cfg** file:

```
vlan router mac multiple enable
```

After adding the command syntax to the **boot.cfg** file and saving your changes, reboot the switch.

When the switch boots, the system software reads from the **boot.cfg** file. All valid command syntax, including **vlan router mac multiple enable**, is initialized and multiple MAC router mode is re-enabled. Because the syntax has been added to the switch's **boot.cfg** file, multiple MAC router mode will remain enabled after subsequent switch reboots.

Viewing Current Multiple MAC Router Mode Status

To view the switch's current MAC router mode status (i.e., whether multiple MAC router mode is enabled or disabled), use the **show vlan router mac status** command. For example:

```
-> show vlan router mac status
  router-mac-multiple  total vlans  router vlans  ip vlans  ipx vlans
-----+-----+-----+-----+-----
                enabled                5                3                3                0
```

In this example, multiple MAC router mode is enabled (the switch's default setting).

For detailed information on multiple and single MAC router modes, refer to the "Configuring VLANs" chapter in the *OmniSwitch 7700/7800/8800 Network Configuration Guide*.

Note. When VLAN router ports are assigned in multiple MAC router mode, the syntax, **mac alloc**, is written to the switch's **boot.cfg** file whenever a **write memory** or **configuration snapshot** command is issued. For example, text similar to the following may appear in the **boot.cfg** file:

```
mac alloc 8 2 1 00:d0:95:6a:68:11
```

This **mac alloc** syntax is not a user command. Therefore, do not attempt to enter this syntax at the CLI prompt. It is system-generated syntax used to ensure that each new router port being assigned receives a unique MAC address. For more information about editing the **boot.cfg** file, see the *OmniSwitch 7700/7800/8800 Switch Management Guide*.

3 Chassis Management Module (CMM)

The Chassis Management Module (CMM) is the management unit for OmniSwitch 8800 switches. In its role as the management unit, the CMM provides key system services, including:

- Console, modem, and Ethernet management port connections to the switch
- Software and configuration management, including the Command Line Interface (CLI)
- Web-based management (WebView)
- SNMP management
- Power distribution
- Switch diagnostics
- Important availability features, including redundancy (when used in conjunction with another CMM), software rollback, temperature management, and power management.

In This Chapter

This chapter provides specifications and descriptions of OmniSwitch 8800 CMMs. In addition, procedures to set up chassis components and procedures to monitor CMMs using Command Line Interface (CLI) commands are also provided. Topics include:

- Descriptions on specifications of CMMs beginning on [page 3-2](#)
- An overview of CMM redundancy on [page 3-9](#)
- An overview of hot swapping CMMs on [page 3-12](#)
- Managing CMMs on [page 3-13](#)
- Monitoring CMMs on [page 3-15](#)

Note. You can also manage and monitor CMMs with WebView, Alcatel's embedded web-based device management application. WebView is an interactive and easy-to-use GUI that can be launched from OmniVista or a web browser. Please refer to WebView's online documentation for more information.

CMM Slot Locations

In a non-redundant (i.e., single CMM) configuration, the CMM can be installed in either Slot A or Slot B of the chassis. In redundant CMM configurations, a CMM is installed at both Slot A and Slot B (refer to [page 3-9](#) for more information on CMM redundancy). These slots run vertically and are located in the center of the chassis. Refer to the figure below.

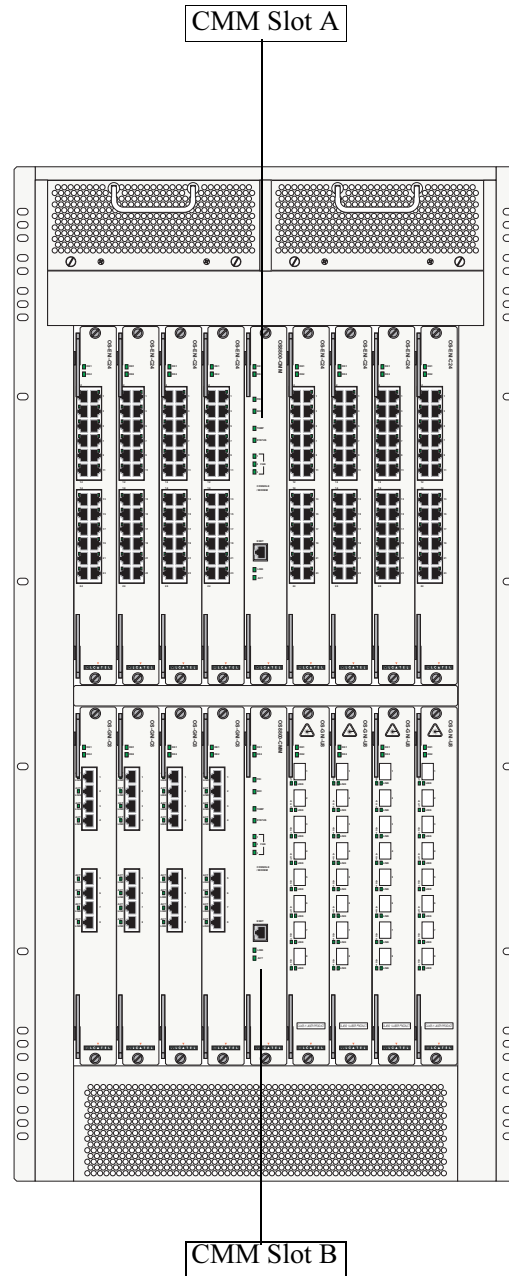

CMM Slot Locations

CMM Front Panel

Redundancy LEDs

PRI. Displays solid green when the CMM is the primary (active) management module.

SEC. Displays solid green when the CMM is the secondary (backup) management module. For detailed information on CMM redundancy, refer to [page 3-9](#).

Temperature and Status LEDs

TEMP. Displays solid green when the CMM is operating within the allowed temperature range. Displays solid amber if a temperature error occurs (i.e., the CMM is operating outside the temperature range).

If the LED indicates a temperature error, you can use the **show temperature** command to access more information. Refer to the *OmniSwitch CLI Reference Guide* for more information.

STATUS. Displays solid green when the Switch Fabric Modules (SFMs) and power supplies are operating normally. Displays solid amber if there is an error in an SFM or power supply.

If the LED indicates an error, you can use the **show fabric** or **show power** command to access more information. Refer to the *OmniSwitch CLI Reference Guide* for more information.

FAN 1. Displays solid green when the two fans in the left front fan tray are running at normal speed. Displays solid amber if a fan error occurs (i.e., one or more fans are not running at normal speed).

FAN 2. Displays solid green when the two fans in the right front fan tray are running at normal speed. Displays solid amber if a fan error occurs (i.e., one or more fans are not running at normal speed).

FAN 3. Displays solid green when the three fans in the rear fan tray are running at normal speed. Displays solid amber if a fan error occurs (i.e., one or more fans are not running at normal speed).

If a fan LED indicates a fan error, you can use the **show fan** command to access more information. Refer to the *OmniSwitch CLI Reference Guide* for more information.

Module Status LEDs

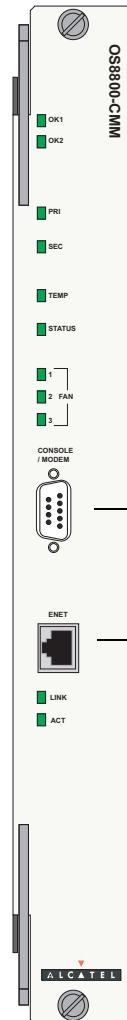

Module Status LEDs

Module Status LEDs

OK1. Hardware Status. Displays solid green when powered on and the CMM has passed hardware diagnostic tests. Displays solid amber when powered on and the CMM has failed hardware diagnostic tests.

OK2. Software Status. Blinks green when the CMM is operational. Displays solid amber when a system software failure occurs. Blinks amber when the software is in a transitional state (e.g., when software is being downloaded to the switch).

Ethernet Management Port LEDs

LINK. Link Integrity Status. Displays solid green when an Ethernet cable connection exists at the CMM's Ethernet management port.

ACT. Flashes green as data is transmitted or received on the CMM's Ethernet management port.

Console/Modem Port. The CMM's front panel provides one RS232 port for console or modem connections. By default, this female DB-9 connector provides a DCE console connection. However, by changing the onboard jumper setting, the port can be changed to a DTE modem connection.

For detailed information on changing the jumper setting, refer to [page 3-7](#).

Ethernet Management Port. The CMM's front panel also provides one Ethernet 10/100BaseT port (Copper RJ45). This port provides out-of-band network management and can be used for Telnet sessions, switch diagnostics, and for downloading software to the switch.

This 10/100BaseT port supports both 10BaseT and 100BaseT with auto-negotiation through the RJ45 connector.

Note: In redundant CMM configurations, the EMP is only operational on the *primary* CMM. For more information on redundant CMM configurations, refer to [page 3-9](#).

CMM Front Panel

CMM Technical Specifications

Flash memory	32 MB (Release 5.1)
DIMM (SDRAM) memory	128 MB (Release 5.1)
Battery backup SRAM	32 K
Serial port	One female DB9 console/modem port; set to console by default, but can be jumper-configured to support a modem connection
Ethernet management port (EMP)	One RJ45 port; provides out-of-band network management and can be used for Telnet sessions or for downloading switch software via FTP
Current draw	Approximately 1.0 amps at 24 volts
Power	24 Watts (approximate)

Ethernet Management Port

The Ethernet 10/100BaseT port located on the CMM's front panel provides out-of-band network management and can be used for Telnet sessions, switch diagnostics, and for downloading switch software via FTP.

The 10/100BaseT port supports both 10BaseT and 100BaseT with auto-negotiation through the RJ-45 connector.

Note. In redundant CMM configurations, the EMP is only operational on the *primary* CMM. You must have a valid Ethernet connection to the EMP on the primary CMM before establishing an EMP connection with the switch. For more information on redundant CMM configurations, refer to [page 3-9](#).

Default IP Address. The default IP address for the EMP is 192.168.1.1; the default gateway address is 192.168.1.254. For information on changing the EMP's default IP address information, refer to the *OmniSwitch 8800 Getting Started Guide*.

Access to the EMP

By default, only devices in the same subnet as the EMP will be able to manage the switch through that port. To allow access to the EMP to devices outside the EMP's local network, you can create a static route between the EMP and the network containing devices requiring access to the EMP.

To create a static route for the EMP, use the **ip static-route** command. The command syntax must include the network IP address as well as the gateway address for the EMP. For example:

```
-> ip static-route 10.11.100.1 gateway 192.168.1.254
```

EMP Cable Requirements

There are specific cable type requirements (i.e., straight-through or crossover) based on the type of device to which the EMP is connecting. Refer to the information below:

EMP to a Switch	Straight-through
EMP to a Computer or Workstation	Crossover

Console/Modem Port

Serial Connection to the Console/Modem Port

The console port, located on the CMM front panel, provides a serial connection to the switch and is required when logging into the switch for the first time. By default, this female DB-9 connector provides a DCE console connection. However, by changing the onboard jumper setting, the port can be changed to a DTE modem connection. Refer to [“Converting the Console Port to a Modem Port” on page 3-7](#) for more information.

Serial Connection Default Settings

The factory default settings for the serial connection are as follows:

baud rate	9600
parity	none
data bits (word size)	8
stop bits	1
X-ON/X-OFF	enabled

Modifying the Serial Connection Settings

If you wish to modify the default serial connection settings (i.e., baud rate, parity, data bits, and stop bits), refer to the following steps.

Note. You must be connected to the switch via the console port before attempting to change serial connection settings. Otherwise, an error message will display.

- 1 Enter **modify boot parameters** at the CLI prompt. The boot prompt displays:

```
Boot >
```

- 2 To change the baud rate, enter **boot serialbaudrate**, followed by the desired baud rate value. Options include 1200, 2400, 4800, 9600 (default), 19200, 38400, 57600, 76800, and 115200. For example:

```
Boot > boot serialbaudrate 19200
```

- 3 To change the parity value, enter **boot serialparity**, followed by the desired parity value. Options include none (default), even, and odd. For example:

```
Boot > boot serialparity even
```

4 To change the data bits (i.e., word size) value, enter **boot serialwordsize**, followed by the number of data bits. Options include 7 and 8 (default). For example:

```
Boot > boot serialwordsize 7
```

5 To change the stop bits value, enter **boot serialstopbits**, followed by the number of stop bits. Options include 1 (default) and 2. For example:

```
Boot > boot serialstopbits 2
```

6 Verify your current changes by entering **show** at the boot prompt:

```
Boot > show
Edit buffer contents:
Serial (console) baud           : 19200
Serial (console) parity         : even
Serial (console) stopbits       : 2
Serial (console) wordsize       : 7
```

(additional table output not shown)

7 You can save your changes to the **boot.params** file by entering **commit file** at the boot prompt:

```
Boot > commit file
```

Note. When the **commit file** command is used, changes will not be enabled until after the next switch reboot.

8 You can also save your changes in real time to the switch's running memory by entering **commit system** at the boot prompt:

```
Boot > commit system
```

Caution. There are two important things to consider when using the **commit system** command to save serial connection changes:

- Output to the terminal may become illegible due to incompatible serial connection settings between the switch and the terminal emulation software.
 - If you use the **commit system** command only, changes will *not* be saved to the switch's **boot.params** file and will be lost if the switch is rebooted. To save changes to the **boot.params** file, refer to step 7.
-

9 Return to the CLI prompt by entering **exit** at the boot prompt.

Configuring X-ON/X-OFF Protocol

By default, X-ON/X-OFF protocol is enabled on the console port. To enable and disable the X-ON/X-OFF protocol on a console port that you are logged into use the `session xon-xoff` command by entering `session xon-xoff` followed by either `enable` or `disable`.

For example, to disable X-ON/X-OFF on a console port enter:

```
-> session xon-xoff disable
```

Note. To enable or disable the X-ON/X-OFF protocol on the secondary CMM you must log into the secondary CMM and then execute the `session xon-xoff` command.

Converting the Console Port to a Modem Port

If you require a modem connection to the switch, you must convert the console port to support modem connections by installing a hardware jumper on the CMM. To configure the console port to support modem connections, refer to the steps below.

Anti-Static Warning. Eliminate any static electricity by grounding yourself properly. Refer to *Using the Grounding Wrist Strap and Chassis Grounding Lug* in [Chapter 5, “Network Interface \(NI\) Modules.”](#)

1 Locate the console port jumpers. The jumpers are located on the CMM’s processor board and are labeled J100 through J102. The factory-default jumper positions (which support a console connection) are shown in the figure below.

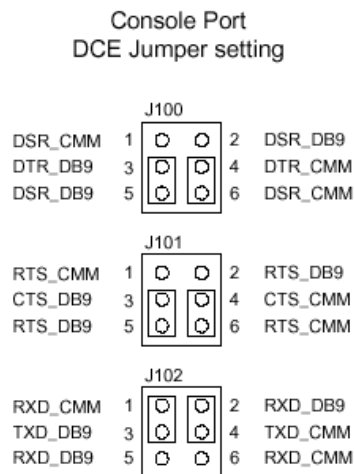

2 Remove each of the jumpers from the J100, J101, and J102 jumper blocks and reinstall them in the positions shown below. To remove a jumper, pull it straight up and away from the jumper block. To replace, slide the jumper over both of the specified pins and gently press down until it meets the jumper block.

Note. Be sure to remove only the jumpers from the J100, J101, and J102 jumper blocks.

Modem Port
DTE Jumper setting

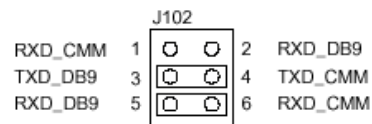
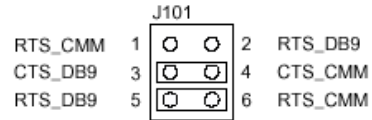
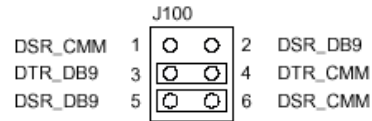

CMM Redundancy

CMM redundancy is one of the switch's most important failover features. For CMM redundancy, two fully-operational CMMs must be installed in the chassis at all times. In addition, the software on the two CMMs must be synchronized. (Refer to [“Synchronizing the Primary and Secondary CMMs”](#) on page 3-10 for more information.)

When two CMMs are running in the switch, one CMM has the primary role and one CMM has the secondary role at any given time. The primary CMM manages the current switch operations while the secondary CMM provides backup (also referred to as “failover”).

In a redundant configuration, if the primary CMM fails or goes offline for any reason, the secondary CMM is instantly notified. The secondary CMM automatically assumes the primary role.

CMM Failover Sequence

The figure below illustrates the CMM failover sequence:

- 1** CMM A (installed in the top Slot A position) is operating in the primary mode. CMM B (installed in the bottom Slot B position) is operating in the secondary mode—i.e., it is functioning as the standby CMM and is ready to take over chassis management functions in the event of a primary CMM failure.
- 2** CMM A fails or is taken offline (e.g., the module is physically removed from the chassis).
- 3** CMM B automatically assumes the primary role.

Ethernet Management Ports (EMPs) and Redundancy. In redundant CMM configurations, the Ethernet Management Port (EMP) is only operational on the *primary* CMM. For additional information on the EMP, refer to [page 3-4](#).

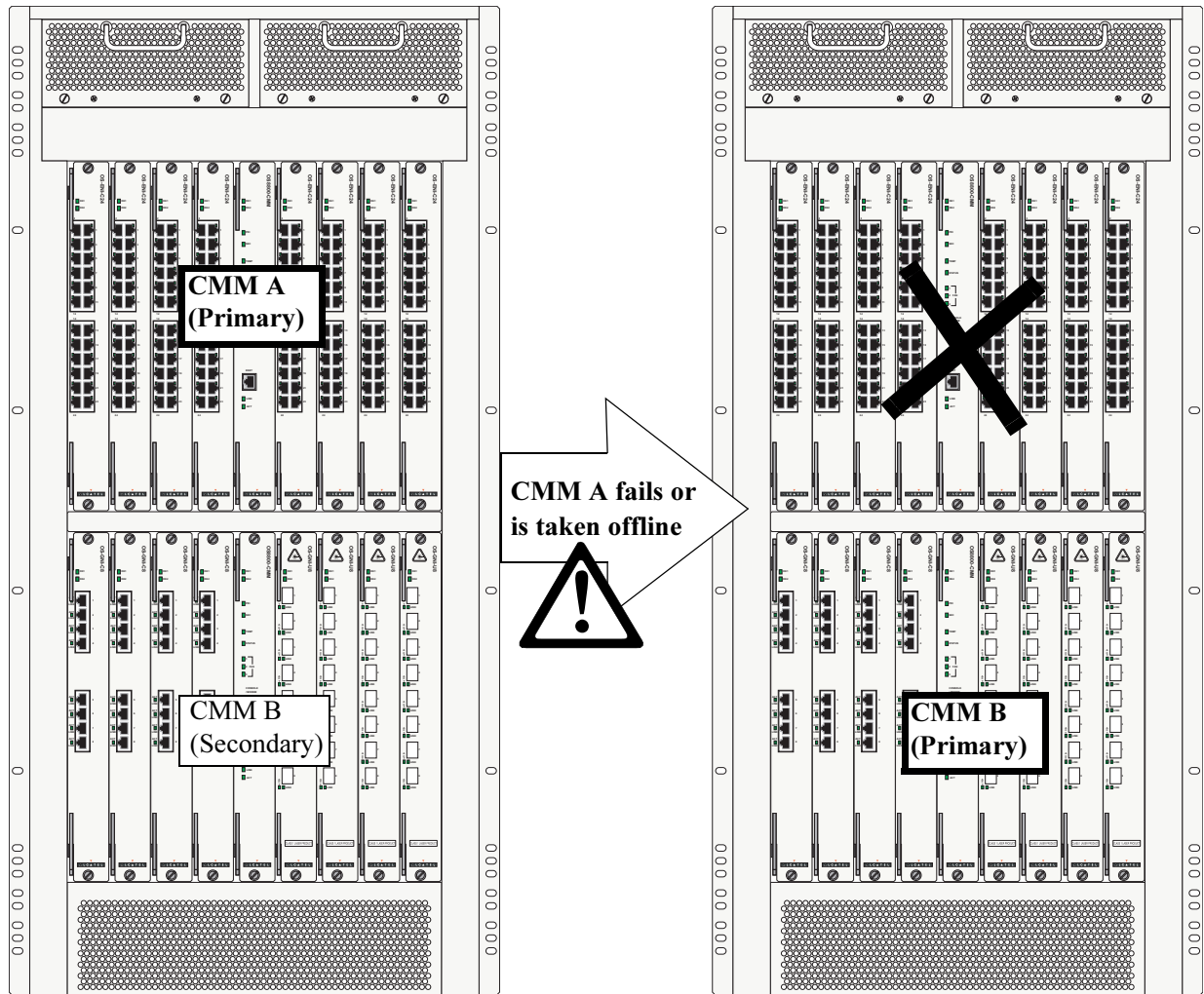

Redundant CMM Failover

Synchronizing the Primary and Secondary CMMs

CMM synchronization refers to the process of copying all files in the `/flash/working` and `/flash/certified` directories of the primary CMM to the `/flash/working` and `/flash/certified` directories of the secondary CMM. This ensures that these directories match exactly on both modules, which prevents the secondary CMM from assuming the primary role with incorrect or outdated software or configuration files in the event of a primary CMM failure.

Important. In order to have effective CMM redundancy, CMMs must be synchronized at all times.

To synchronize the primary and secondary CMMs, enter the following command at the CLI prompt:

```
-> copy flash-synchro
```

For more information on CMM synchronization and managing the **/flash/working** and **/flash/certified** directories, refer to the “Managing CMM Directory Content” chapter in the *OmniSwitch 7700/7800/8800 Switch Management Guide*.

Hot Swapping CMMs

Hot swapping a CMM refers to the action of adding, removing, or replacing a CMM while the switch is operating. You are not required to enter a CLI command in order to hot swap CMMs. This function can be performed on the fly by simply removing the module from the switch chassis.

Module Presence Signalling

On-the-fly module removal is provided through the presence signalling function. All modules in the switch send out “presence signals.” When a module sends out this signal, it is essentially advertising to all other modules in the switch that it is present in the chassis. When a module is present, information such as its module type (primary CMM, secondary CMM, SFM, ENI, or GNI) becomes available for monitoring functions.

The presence signal is controlled through a shortened connector pin that interfaces with the switch’s backplane. Because this connector pin is shorter than the module’s other backplane connectors, the presence signal connection is the first to become interrupted when a board is removed from the chassis. This allows the switch additional time (approximately 5 ms) to complete the current transfer of data before the module is completely disconnected. (In order to avoid data loss, the switch immediately stops incoming traffic and flushes outgoing traffic on the module being removed.)

Note. Although presence signalling is designed to maintain data flow on the switch during the hot swap procedure, uninterrupted data flow cannot be guaranteed. As a result, you should not hot swap CMMs during critical network activity.

Hot Swap Requirements

Important. There are important conditions that must be met before a CMM can be hot swapped. Be sure to read the information below before attempting to hot swap a CMM.

Removing or Replacing CMMs

You must have CMM redundancy before removing or replacing a CMM. If the switch has only one CMM installed and you attempt to hot swap the module, all switch management functions as well as network data flow will be terminated. For important information on CMM redundancy, refer to [page 3-9](#).

Also, before removing or replacing a primary CMM in a redundant configuration, verify that the primary and secondary CMMs are synchronized. Otherwise, data flow and switch management functions may be interrupted due to incorrect or outdated software when the secondary CMM takes over. For more information, refer to “[Synchronizing the Primary and Secondary CMMs](#)” on [page 3-10](#).

Adding a Secondary CMM

A secondary (or *redundant*) CMM can be added to the chassis at any time without disturbing the operation of the switch. However, you should synchronize the primary and secondary CMMs immediately after the hot swap in order to have effective redundancy. For more information, refer to [“Synchronizing the Primary and Secondary CMMs”](#) on page 3-10.

Note. For detailed instructions on physically installing and removing modules (both NIs and CMMs), refer to [Chapter 5, “Network Interface \(NI\) Modules.”](#)

Managing CMMs

Refer to the “Managing CMM Directory Content” chapter in the *Switch Management Guide* for detailed information on managing CMMs.

Reloading a CMM

You can reload either the primary or secondary CMM using the CLI’s **reload** command. For information on using this command, refer to the “Managing CMM Directory Content” chapter in the *Switch Management Guide*. A CMM reload is essentially a soft boot of the module. Note that you can reload only one CMM at a time; the primary and secondary CMMs cannot be reloaded simultaneously.

Reloading the Primary CMM

If the primary CMM is reloaded, the secondary CMM automatically takes over primary management functions. In other words, the secondary CMM becomes the primary CMM as soon as the reload is initiated. The reloaded CMM then assumes the secondary—or *redundant*—role when the reload sequence is complete.

Reloading the Secondary CMM

If the secondary CMM is reloaded, only the secondary CMM is affected. The primary CMM continues all operations without interruption.

Switching the Primary and Secondary Roles

The primary and secondary CMMs can trade roles. In other words, the CMM that is currently functioning as the secondary CMM can be assigned to “take over” the role of the primary CMM. The primary CMM then assumes the secondary role. Because this action is coordinated between the two CMMs, switch management functions are maintained during the takeover.

To manually designate the secondary CMM to assume the primary role, enter the **takeover** command at the CLI prompt. For example:

```
-> takeover
```

The PRI and SEC LEDs on the CMM’s front panel display the CMM’s current role (i.e., primary or secondary). Refer to [page 3-3](#) for more information. You can also use the **show running-directory** command to display whether the CMM you are currently logged in to is primary or secondary. For example:

```
CONFIGURATION STATUS
  Running CMM           : PRIMARY,
  CMM Mode              : DUAL CMMs,
  Current CMM Slot     : A,
  Running configuration : WORKING,
  Certify/Restore Status : CERTIFY NEEDED
SYNCHRONIZATION STATUS
  Flash Between CMMs   : NOT SYNCHRONIZED,
  Running Configuration : SYNCHRONIZED,
  NIs Reload On Takeover : ALL NIs
```

In this example, the user is currently logged in to the primary CMM.

Note. Before using the **takeover** command, verify that the primary and secondary CMMs are synchronized. Otherwise, data flow and switch management functions may be interrupted due to incorrect or outdated software when the secondary CMM takes over. For more information, refer to [“Synchronizing the Primary and Secondary CMMs” on page 3-10](#).

Monitoring CMMs

Front Panel LEDs

The CMM provides a series of status LEDs on the module's front panel. These LEDs offer basic status information for the following switch functions:

- CMM hardware operation (OK1)
- System software (OK2)
- CMM redundancy (PRI and SEC)
- Chassis ambient air temperature (TEMP)
- SFM and power supply status (STATUS)
- Fan status (FAN 1, FAN 2, FAN 3)
- Ethernet management port (LINK and ACT)

Refer to [page 3-3](#) for detailed information on CMM front panel LEDs.

Accessing General CMM Information

The switch's Command Line Interface (CLI) offers CMM monitoring commands. These commands allow you to access general CMM hardware information as well as the current operating status of CMM-related components.

CMM Hardware Information

The **show cmm** and **show hardware info** commands are used to display general hardware information for the CMM(s) installed in the chassis.

Use the **show cmm** command to display the following information:

- Model name and description for each CMM
- Part number and serial number
- Hardware revision level
- Manufacture date
- Firmware version number
- Administrative and operating status
- Additional information, such as power control checksum, ASIC information, and chassis MAC Address (see [page 3-17](#) for information on MAC address storage)

For a detailed information on the **show cmm** command, including output table descriptions, refer to the *OmniSwitch CLI Reference Guide*.

The **show hardware info** command displays the following information:

- CPU type
- Flash manufacturer and flash size
- RAM manufacturer and RAM size
- NVRAM battery status
- Jumper settings
- BootROM and Miniboot versions
- FPGA version(s)

For detailed information on the **show hardware info** command, including output table descriptions, refer to the *OmniSwitch CLI Reference Guide*.

Operating Status of CMM-Related Components

The CMM contains the switch's temperature sensor and monitors fan operation. If the TEMP, STATUS, FAN 1, FAN 2, or FAN 3 LEDs on the CMM's front panel indicate an error, you can use the **show temperature**, **show fabric**, or **show fan** commands to access additional status information.

For information on reading temperature and fan status LEDs, refer to [page 3-3](#).

For information on using the **show temperature** and **show fan** commands, as well as information on temperature management and fan maintenance, refer to [Chapter 2, "Chassis and Power Supplies."](#) For information on the **show fabric** command, refer to [Chapter 4, "Switch Fabric Module \(SFM\)."](#)

CLI Commands Supported on Both the Primary and Secondary CMMs

Although most CLI commands are executed when logged into the primary CMM, there is a group of commands that is supported when logged in to either the primary or secondary CMM. For a list of these commands, refer to the tables below. The tables are grouped by chapter according to the *OmniSwitch CLI Reference Guide*.

CMM Commands

reload takeover install	debug chassis auto-reboot show running-directory	show reload show microcode
--------------------------------	---	-----------------------------------

Chassis Management and Monitoring Commands

show system show hardware info show chassis	show cmm show ni show module	show module long show module status show fabric
--	-------------------------------------	--

File Management Commands

cd	delete	ed
pwd	cp	vi
mkdir	mv	view
rmdir	move	tty
ls	chmod	show tty
dir	attrib	rz
rename	fsck	more
rm	newfs	install

Switch Logging and Monitoring Commands

swlog	debug ktrace	debug systrace show
swlog appid level	debug ktrace appid level	debug systrace show log
swlog output	debug ktrace show	debug memory monitor
show log swlog	debug systrace	debug memory monitor show log
show swlog	debug systrace appid level	

Memory Monitoring Commands

show log pmd

Session Management Commands

session timeout

Chassis-Based MAC Address

The switch's base MAC address is not tied to the CMM. Instead, the switch provides an EEPROM card near the chassis backplane that stores the MAC address. This allows the switch to retain the MAC address when a CMM is removed or replaced. For detailed information on MAC address management on the switch, refer to the "Managing MAC Addresses and Ranges" chapter in the *OmniSwitch 7700/7800/8800 Switch Management Guide*.

MAC EEPROM Redundancy. A second EEPROM is provided for redundancy. An EEPROM card can be removed and replaced in the field by an authorized Alcatel Support Engineer in the unlikely event of an EEPROM failure.

Pinouts

RS232 Port – Female DB9 Connector Pinout

Pin Number	Signals as DCE Console Port	Signals as DTE Modem Port
1	Not used	Not used
2	RXD (from CMM)	RXD (to CMM)
3	TXD (to CMM)	TXD (from CMM)
4	Not used	DTR (from CMM)
5	Ground	Ground
6	Not used	DSR (to CMM)
7	Not used	RTS (from CMM)
8	Not used	CTS (to CMM)
9	Not used	Not used
Shell	Chassis ground	Chassis ground

4 Switch Fabric Module (SFM)

The OmniSwitch 8800 OS8800-SFM Switch Fabric Modules (SFMs) allow for communication between the various NIs and CMMs on the OmniSwitch 8800. SFMs are the link between the other removable components of a switch (NIs and CMMs). A complete fabric consists of four SFM modules plus one optional module for redundancy.

SFMs are located in the rear of the switch in numbered slots specifically designed for SFMs. Other NIs or CMMs will not function in SFM slots.

Each Fabric Module contains two ASICs which provide the store-and-forward switching fabric function for the OmniSwitch 8800. The ASIC is bit-sliced; a group of eight ASICs operates together as a single synchronized fabric.

In This Chapter

This chapter includes information on how to install, remove, and monitor Switch Fabric Modules in an OmniSwitch 8800. It also explains the basic functions of the SFM. The information is contained in the following sections:

- [“SFM Slot Locations” on page 4-2](#)
- [“SFM Front Panel” on page 4-3](#)
- [“SFM Redundancy” on page 4-4](#)
- [“Adding and Removing SFM Modules” on page 4-5](#)
- [“SFM Power Commands” on page 4-13](#)
- [“Monitoring SFM Modules” on page 4-14](#)

SFM Slot Locations

Switch Fabric Modules are located in the rear of the switch chassis below the fans and above the power supplies, as shown:

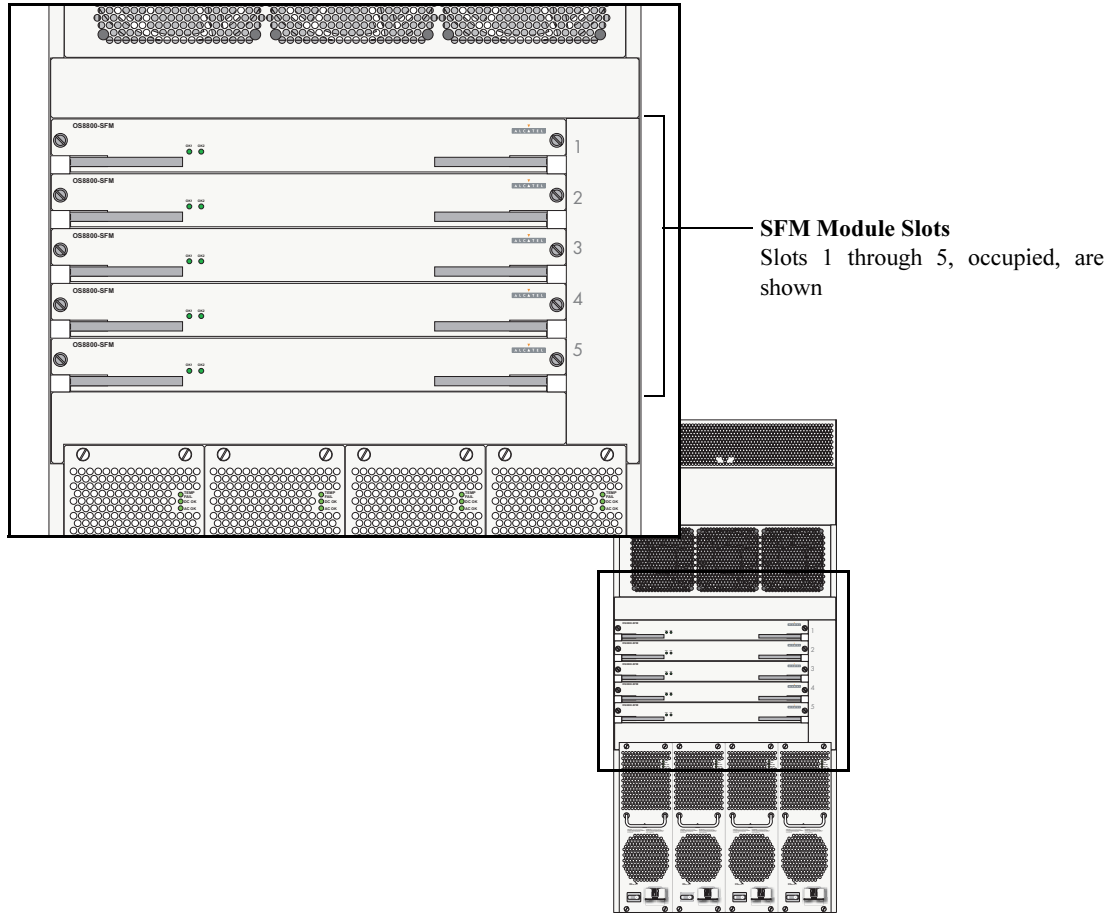

SFM Slot Locations on the Back of the Chassis

The fabric board slots are numbered 1 to 5. In order for the switch to function, slots 1 through 4 must contain an SFM. Slot 5 is used for SFM redundancy, in the event one of the other SFMs fail. The switch will function if slot 5 is empty.

SFM Front Panel

The following diagram shows the front panel of the SFM with its LEDs explained:

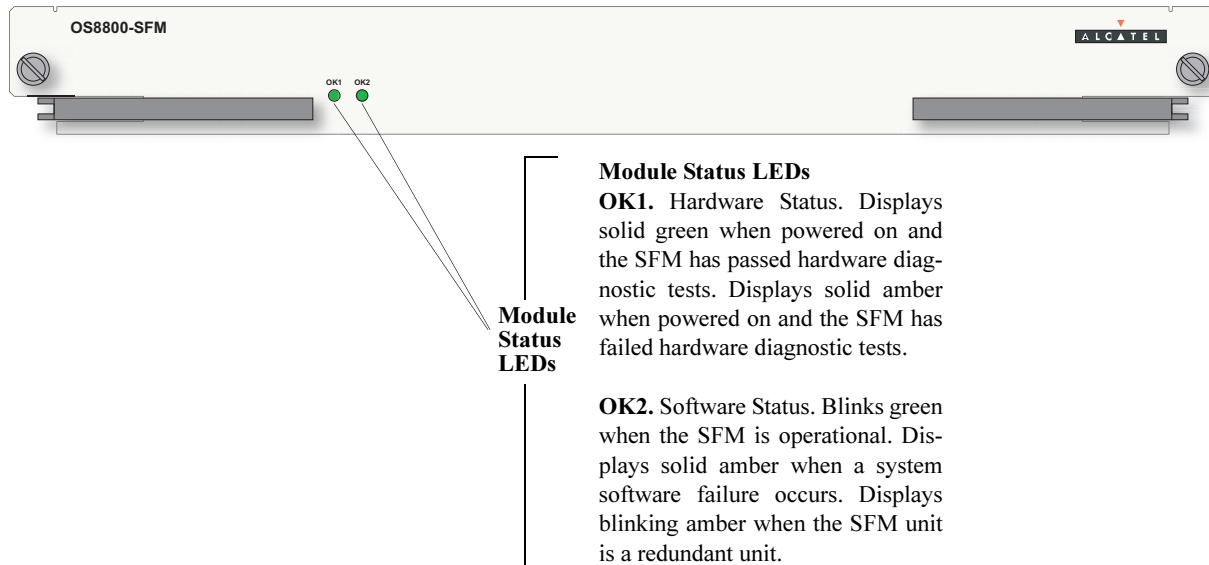

SFM Front Panel

SFM Technical Specifications

Minimum number of SFMs required in an OS8800	4
Minimum number of SFMs required in an OS8800 in a redundant configuration	5
Current draw	Approximately 2.5 amps at 24 volts
Power	60 Watts (approximate)

SFM Redundancy

The OmniSwitch 8800 allows for redundancy in the Switch Fabric Modules. In order for the switch to operate, there must be four working SFMs in place. A fifth SFM can be added in case one of the four fails.

If an SFM fails, and a redundant SFM is in place, then the redundant SFM takes over for the failed SFM, with no loss of switch running time. A warning message is sent to notify the switch administrator that a failure has occurred and that the redundant SFM has taken over.

SFM Failover Sequence

The figure below illustrates the SFM failover sequence:

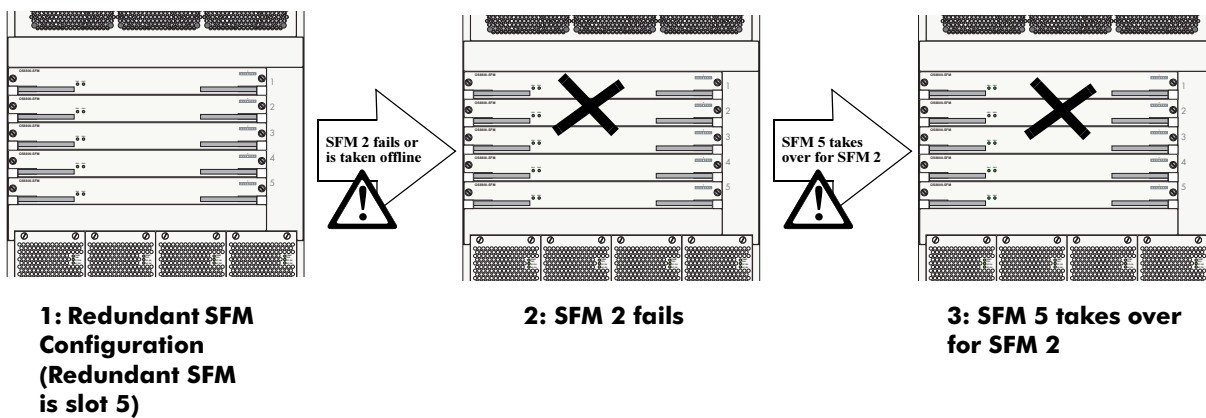

Redundant SFM Failover

- 1 The OmniSwitch 8800 is running with the SFMs in slots 1 through 4 controlling traffic. The SFM in slot 5 is a redundant module.
- 2 The SFM in slot 2 fails.
- 3 The redundant SFM in slot 5 takes over for the SFM in slot 2. The switch is now functional again with the SFMs in slots 1, 3, 4, and 5 handling traffic.

Adding and Removing SFM Modules

Using the Grounding Wrist Strap and Chassis Grounding Lug

Because electrostatic discharge (ESD) can damage switch components such as the Switch Fabric Modules, you must always ground yourself properly before removing or adding a module. For this purpose, Alcatel provides a grounding wrist strap and a grounding lug located near the bottom-right of the chassis. To properly ground yourself, follow the steps below.

- 1 Fasten the grounding strap to your wrist. (A grounding strap was provided in your OmniSwitch 8800 series ship kit.)
- 2 Insert the wrist strap's connector pin (located at the end of the strap's tether) into the grounding lug near the bottom-right of the chassis.

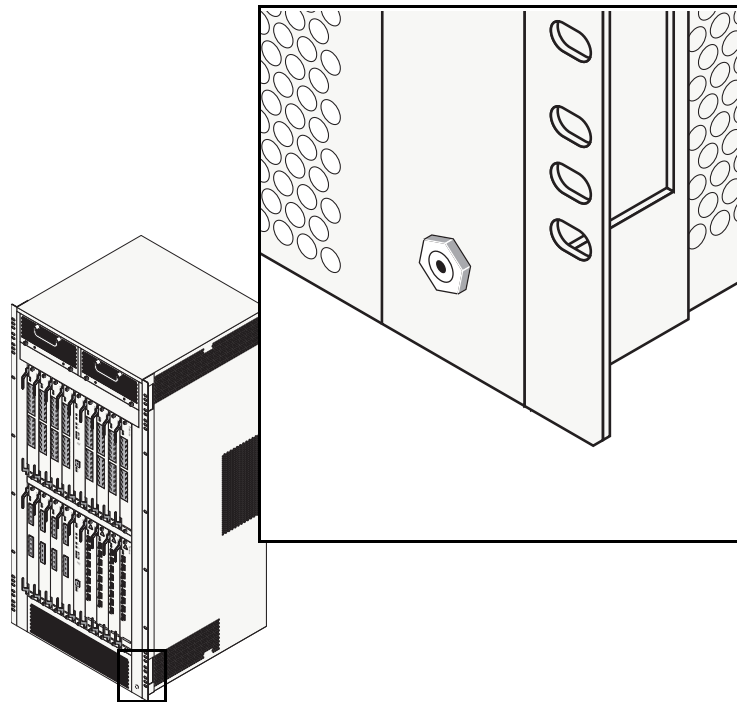

Note. For the grounding wrist strap to be effective in eliminating ESD, power supplies must be installed in the chassis and plugged into grounded AC outlets.

Module Slot Positions

When installing an SFM in the chassis, consider the following:

- Switch Fabric Modules may be installed in any slot position from 1 through 5 on the back of OmniSwitch 8800s.
- At least 4 modules in slots 1 through 4 must be installed for the switch to work.
- CMMs or NI modules cannot be installed the rear chassis slots.

More Information on Slot Numbering. For a diagram showing the chassis layout and slot positions, refer to [Chapter 2, “Chassis and Power Supplies.”](#)

Adding a Module

To install an Switch Fabric Module, follow the steps below.

- 1 Holding the module in both hands, carefully slide it into the chassis card guide. The component side of the board should face up.

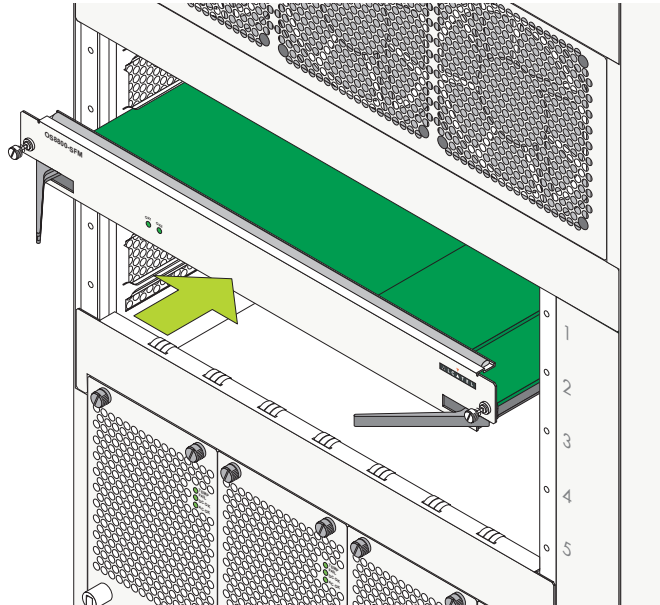

Note. The module should slide in easily. Do not force the module into the slot. If any resistance is encountered, ensure the module is aligned properly in the card guide.

2 When the module is nearly seated in the slot, be sure that the two extractor levers—one on left of the module and one on the right—are slightly opened (approximately 30 degrees). This allows the notch on each extractor lever to grasp the rail on the chassis. Once the notches have grasped the rail, press both extractor levers inward simultaneously until the module is firmly seated.

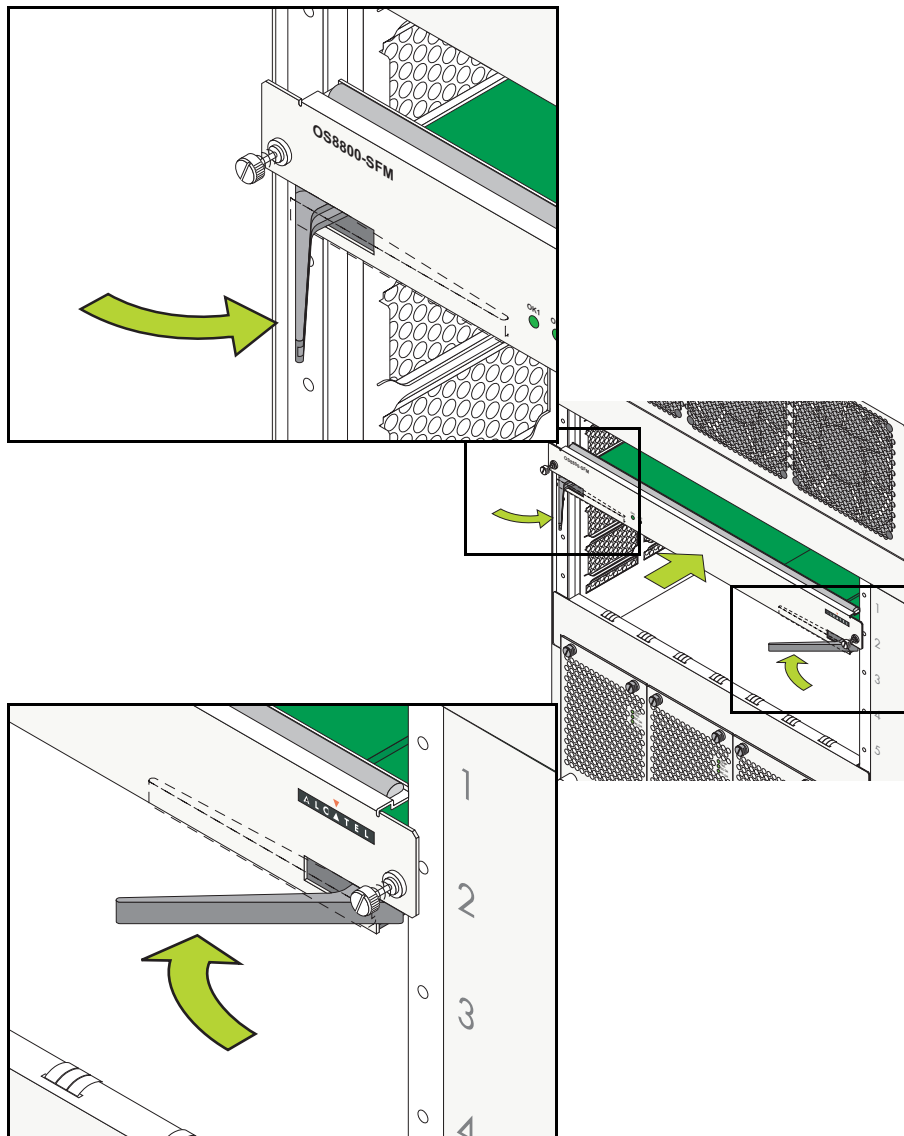

3 Once the module is firmly seated, secure the module to the chassis by tightening the two captive screws. *Be sure not to overtighten the captive screws. If you use a screwdriver, the torque used to tighten the screws must not exceed 2.3 inch pounds.*

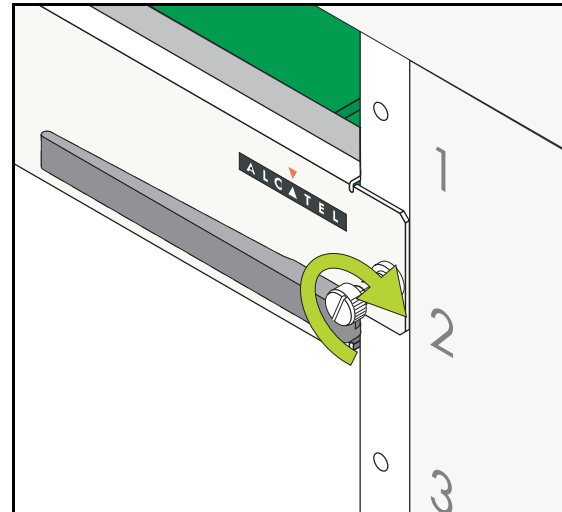
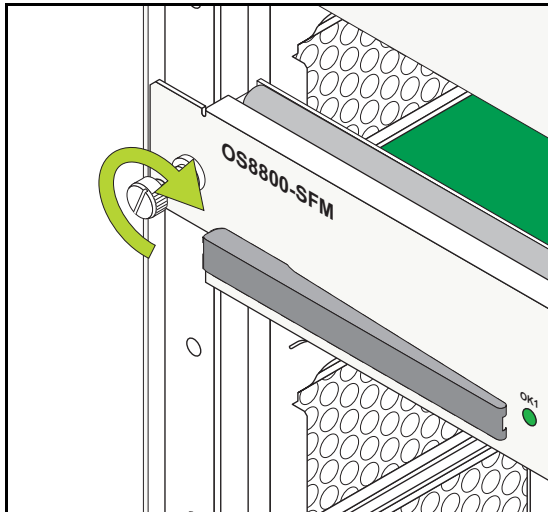

Removing a Module

To remove a Switch Fabric Module (SFM) from the chassis, follow the steps below.

- 1 Loosen the module's two captive screws that secure the module to the chassis. Be sure that both captive screws are completely disengaged from the threaded holes in the chassis before continuing.

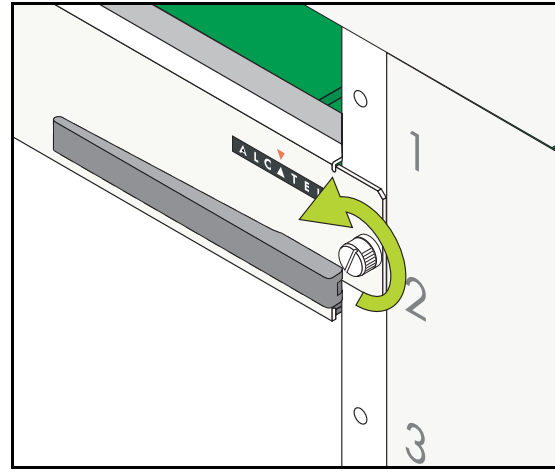
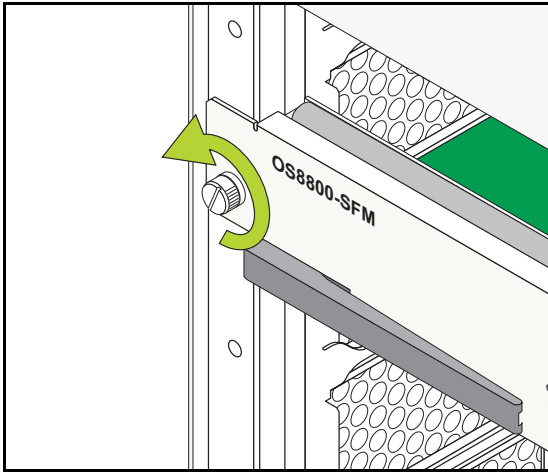

- 2 Simultaneously pull the two module extractor levers—one to the left of the module and one to the right—until the module disengages from the chassis.

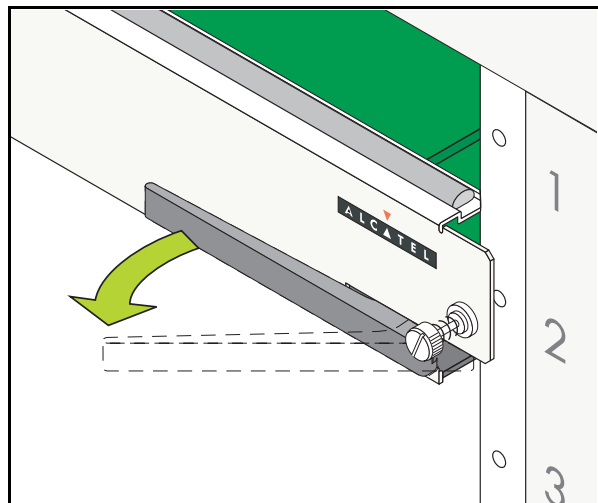
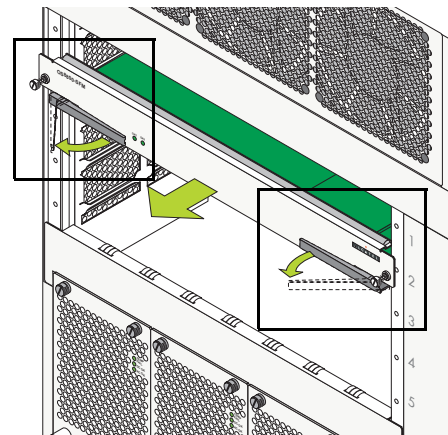
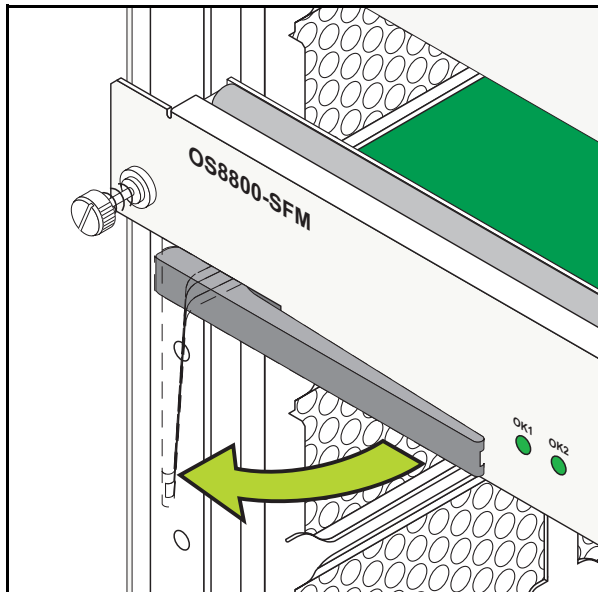

- 3 Holding the module in both hands, carefully slide it out of the chassis along the card guide. The module should slide out easily. Do not force the module from the slot.

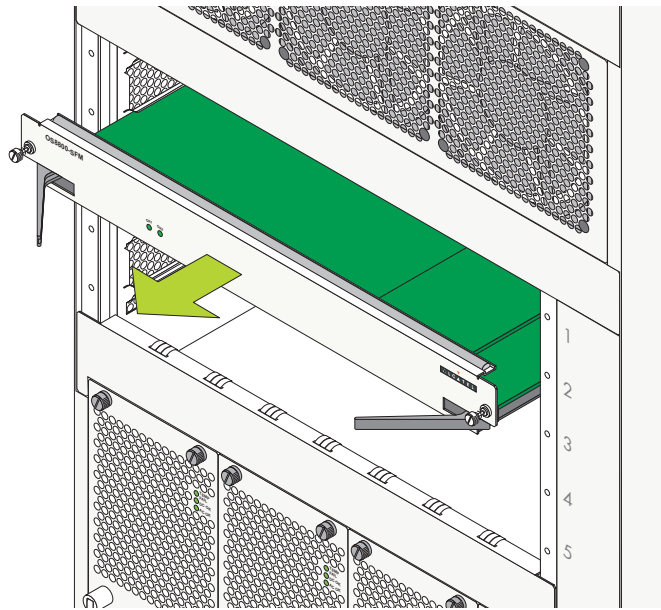

Note. For detailed instructions on physically installing and removing NI modules, refer to [Chapter 5, “Network Interface \(NI\) Modules.”](#)

SFM Power Commands

SFMs in a chassis are in one of three power states:

- **Power on.** The SFM is up and running as one of the components of the switch fabric.
- **Power off.** The SFM is down and not participating in the switch fabric, nor will it takeover in the event that one of the powered on switches fails.
- **Standby.** The SFM is up, but is waiting as a redundant SFM in case of the failure of one of the other SFMs.

The normal state of an SFM is power on, and at least four powered SFMs are necessary for the OmniSwitch 8800 to function. If a fifth SFM is installed, it is possible to change the power state of any of the SFMs in the chassis.

Powering On an SFM

To change the state of an SFM to power on, enter the **power fabric** command with the SFM slot number, as shown:

```
-> power fabric 4
```

The SFM in slot 4 of the chassis would now power up. The SFM slot numbers and status can be viewed using the **show fabric** command.

The **power fabric** command is only valid when there are five SFMs in a chassis (four running and one redundant).

Powering Off an SFM

To change the state of an SFM to power off, enter the **power fabric** command with the SFM slot number and the **no** keyword, as shown:

```
-> no power fabric 4
```

The SFM in slot 4 of the chassis would now power down. The SFM slot numbers and status can be viewed using the **show fabric** command.

The **power fabric** command is only valid when there are five SFMs in a chassis (four running and one redundant).

Setting an SFM to Standby

To change the state of an SFM to standby, enter the **fabric standby** command with the SFM slot number, as shown:

```
-> fabric standby 4
```

The SFM in slot 4 of the chassis would now revert to standby mode. In standby mode, this SFM is considered the redundant SFM and is ready to take the place of another SFM that fails. The SFM slot numbers and status can be viewed using the **show fabric** command.

The **fabric standby** command is only valid when there are five SFMs in a chassis (four running and one redundant).

Monitoring SFM Modules

Front Panel LEDs

The SFM provides a series of status LEDs on the module's front panel. These LEDs offer basic status information for the following switch functions:

- SFM hardware operation (OK1). Hardware Status. Displays solid green when powered on and the SFM has passed hardware diagnostic tests. Displays solid amber when powered on and the SFM has failed hardware diagnostic tests.
- System software (OK2). Software Status. Blinks green when the SFM is operational. Displays solid amber when a system software failure occurs. Displays blinking amber when the SFM unit is a redundant unit.

Accessing General SFM Information

The switch's Command Line Interface (CLI) offers SFM monitoring commands. These commands allow you to access general SFM hardware information as well as the current operating status.

The **show fabric** command allows you to view the operating parameters of the SFMs currently installed in the OmniSwitch 8800. A display for each SFM is given, including the redundant SFM. For example:

```
-> show fabric

Fabric Number 1
  Model Name:          OS8800-SFM ,
  Description:         SWITCH FABRIC MOD,
  Part Number:         901979-10,
  Hardware Revision:   102,
  Serial Number:       2366076P,
  Manufacture Date:    SEP 10 2002,
  Firmware Version:    ,
  Admin Status:        POWER ON,
  Operational Status:  UP,
  Power Provision:     100

Fabric Number 2
  Model Name:          OS8800-SFM ,
  Description:         SWITCH FABRIC MOD,
  Part Number:         901979-10,
  Hardware Revision:   102,
  Serial Number:       2366115P,
  Manufacture Date:    SEP 13 2002,
  Firmware Version:    ,
  Admin Status:        POWER ON,
  Operational Status:  UP,
  Power Provision:     100

Fabric Number 3
  Model Name:          OS8800-SFM ,
  Description:         SWITCH FABRIC MOD,
  Part Number:         901979-10,
  Hardware Revision:   102,
  Serial Number:       2366078P,
  Manufacture Date:    SEP 10 2002,
  Firmware Version:    ,
  Admin Status:        POWER ON,
  Operational Status:  UP,
  Power Provision:     100

Fabric Number 4
  Model Name:          OS8800-SFM ,
  Description:         SWITCH FABRIC MOD,
  Part Number:         901979-10,
  Hardware Revision:   102,
  Serial Number:       2366167P,
  Manufacture Date:    SEP 10 2002,
  Firmware Version:    ,
  Admin Status:        POWER ON,
  Operational Status:  UP,
  Power Provision:     100
```

Output continued on next page.

```
Fabric Number 5
Model Name:           OS8800-SFM ,
Description:          SWITCH FABRIC MOD,
Part Number:          901979-10,
Hardware Revision:    102,
Serial Number:         2366167P,
Manufacture Date:     SEP 10 2002,
Firmware Version:     ,
Admin Status:         POWER ON,
Operational Status:   SECONDARY,
Power Provision:      100
```

Each of the modules in the switch chassis has its own display. If there are only four modules in the chassis, only four displays appear. The redundant SFM is known by the word **SECONDARY** in the **Operation Status** field.

5 Network Interface (NI) Modules

Several Ethernet Network Interface (ENI), Gigabit Network Interface (GNI), and 10 Gigabit Network Interface (10GNI) modules are currently available for OmniSwitch 8800 switches. These modules come in a variety of port speeds, including auto-sensing 10/100 Mbps Ethernet, Gigabit Ethernet (1 Gbps), and 10 Gigabit Ethernet (10 Gbps). In addition, these modules come with several connector types, including copper RJ-45 connectors on 10/100 and Gigabit Ethernet modules, LC connectors on wire-rate and high-density Gigabit Ethernet modules, and SC connectors on 10 Gigabit modules.

Note. See [Chapter 4, “Switch Fabric Module \(SFM\),”](#) for descriptions, specifications, and procedures for SFMs.

In This Chapter

This chapter provides specifications and descriptions of all ENI, GNI, and 10GNI modules currently available for OmniSwitch 8800 switches. In addition, procedures using Command Line Interface (CLI) commands to manage and monitor ENI, GNI, and 10GNI modules are also provided. Specifications, descriptions, and procedures in this chapter include:

- Specifications and descriptions of ENI modules on [page 5-3](#)
- Specifications and descriptions of GNI modules on [page 5-6](#)
- Specifications and descriptions of 10GNI modules on [page 5-18](#)
- An overview of Smart Continuous Switching on [page 5-26](#)
- Procedures for managing NI modules on [page 5-26](#)
- Procedures for monitoring NI modules on [page 5-27](#)
- An overview of hot swapping on [page 5-28](#)
- Procedures for adding and removing Chassis Management Modules (CMMs) and NI modules on [page 5-29](#)
- Pinouts of RJ-45 ports on ENI and GNI modules on [page 5-34](#)
- An overview of proper handling of fiber optic cables on [page 5-35](#).

Note. You can also manage and monitor ENI, GNI, and 10GNI modules with WebView, Alcatel's embedded web-based device management application. WebView is an interactive and easy-to-use GUI that can be launched from OmniVista or a web browser. Please refer to WebView's online documentation for more information.

ENI Modules

The Ethernet Network Interface (ENI) module provides 10/100 Mbps Ethernet connectivity for OmniSwitch 8800 switches.

The following ENI module is available:

- **OS8-ENI-C24.** Provides 24 twisted-pair ports, individually configurable as 10BaseT or 100BaseTX. Refer to [page 5-4](#) for detailed information on this module.

Additional Features

ENI modules also provide the following features:

- Hardware-enhanced Layer 2 switching and Layer 3 routing capacity.
- Bi-directional wire speed switching on all ports.
- Built-in Queue Manager, providing system buffering, QoS priority, and bandwidth control features.
- Individual NI reload. Refer to [page 5-26](#) for more information.
- On-the-fly hot swapping. Refer to [page 5-28](#) for more information.
- LED-based monitoring. Refer to [page 5-27](#) for more information.
- NI support during CMM failover. Refer to [“Smart Continuous Switching” on page 5-26](#) for details.

OS8-ENI-C24 Front Panel

Ethernet Port LEDs

Each Ethernet port has a built-in corresponding LED. This LED indicates the link and activity status for each Ethernet port. The LED displays green when a valid Ethernet cable connection exists. Flashes green as data is transmitted or received on the port.

Refer to the illustration below for LED locations.

LED Location

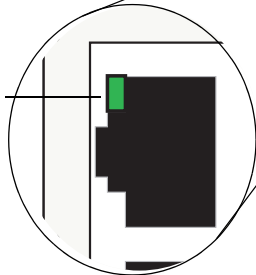

Ethernet Port

Module Status LEDs

Module Status LEDs

OK1. Hardware Status. Displays solid green when powered on and the ENI has passed hardware diagnostic tests. Displays solid amber when powered on and the ENI has failed hardware diagnostic tests.

Module Status LEDs

OK2. Software Status. Blinks green when the ENI is operational and has successfully loaded software. Displays solid amber when powered on and the ENI has failed to load software.

Ethernet Ports

The OS8-ENI-C24 module provides 24 Ethernet ports. These ports are twisted-pair and are individually configurable as 10BaseT or 100BaseTX. The ports use RJ-45 connectors.

Refer to the Technical Specifications table on [page 5-5](#) for more information.

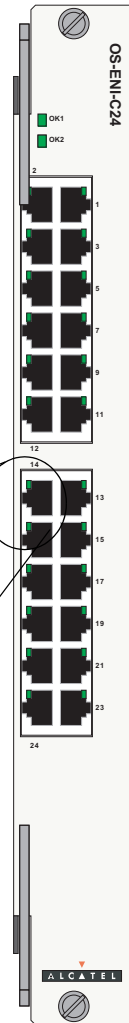

OS8-ENI-C24 Front Panel

OS8-ENI-C24 Technical Specifications

Number of ports	24 twisted-pair, individually configurable as 10BaseT or 100BaseTX.
Connector type	RJ-45
Standards supported	IEEE 802.3u, IAB RFCs 826, 894
Data rate	10 or 100 Mbps (full or half duplex)
Maximum frame size	1553 bytes
MAC addresses supported	32000 per Network Interface (NI) module
Connections supported	10BaseT hub or device or 100BaseTX hub or device
Cable supported	10BaseT: unshielded twisted-pair (UTP) 100BaseTX: unshielded twisted-pair (UTP), Category 5, EIA/TIA 568 or shielded twisted-pair (STP), Category 5, 100 ohm
Maximum cable distance	100 meters
Current draw	1.8 amps at 24 volts
Power	44 watts (approximate)

GNI Modules

Gigabit Ethernet Network Interface (GNI) modules provide up to 24 1000 Mbps (1 Gbps) connections per module. GNI modules can be used for backbone connections in networks where Gigabit Ethernet is used as the backbone media. GNI modules can also be used in the wiring closet.

The following wire-rate 1 Gbps GNI modules are available:

- **OS8-GNI-C8.** Provides eight 1000BaseT twisted-pair ports. Refer to [page 5-7](#) for detailed information on this module.
- **OS8-GNI-U8.** Provides eight MiniGBIC slots. Refer to [page 5-9](#) for detailed information on this module.

The following high-density 1 Gbps GNI modules are available:

- **OS8-GNI-U24.** Provides 24 MiniGBIC slots. Refer to [page 5-11](#) for detailed information on this module.
- **OS8-GNI2-U24.** A second-generation version of the original OS8-GNI-U24. Provides 24 MiniGBIC slots. Refer to [page 5-11](#) for detailed information on this module.
- **OS8-GNI-C24.** Provides 24 auto-sensing twisted-pair ports, individually configurable as 10BaseT, 100BaseTX, or 1000BaseT. Refer to [page 5-16](#) for detailed information on this module.
- **OS8-GNI2-C24.** A second-generation version of the original OS8-GNI-C24. Provides 24 auto-sensing twisted-pair ports, individually configurable as 10BaseT, 100BaseTX, or 1000BaseT. Refer to [page 5-16](#) for detailed information on this module.

A MiniGBIC is a Gigabit Ethernet port module that is hot-pluggable—i.e., it can be installed or removed while the GNI is powered on and operating without the risk of damage to the MiniGBIC module or the host circuitry. Alcatel MiniGBICs are Small Form-factor Pluggable (SFP) MSA (Multi Source Agreement) compliant.

For information on installing MiniGBICs, refer to [page 5-14](#).

Three MiniGBIC types are available for OS8-GNI-U8 and OS8-GNI-U24 modules:

- **MINIGBIC-SX**—1000BaseSX multimode fiber, supports distances up to 550 meters; uses LC connectors
- **MINIGBIC-LX**—1000BaseLX single mode fiber, supports distances up to 10 km; uses LC connectors
- **MINIGBIC-LH-70**—1000BaseLH long haul fiber, supports distances up to 70 km; uses LC connectors

Like ENI modules, GNI modules are also supported during CMM failover. Refer to [“Smart Continuous Switching” on page 5-26](#) for details.

See [“Handling Fiber and Fiber Optic Connectors” on page 5-35](#) for proper handling of LC connectors and fiber-optic cable.

OS8-GNI-C8 Front Panel

Module Status LEDs

OK1. Hardware Status. Displays solid green when powered on and the GNI has passed hardware diagnostic tests. Displays solid amber when powered on and the GNI has failed hardware diagnostic tests.

OK2. Software Status. Blinks green when the ENI is operational and has successfully loaded software. Displays solid amber when powered on and the GNI has failed to load software.

Gigabit Ethernet Port LEDs

ACT. Flashes green when data is transmitted or received on the corresponding Gigabit Ethernet port.

LINK. Link Integrity Status. Displays solid green when a fiber cable connection exists at the corresponding Gigabit Ethernet port.

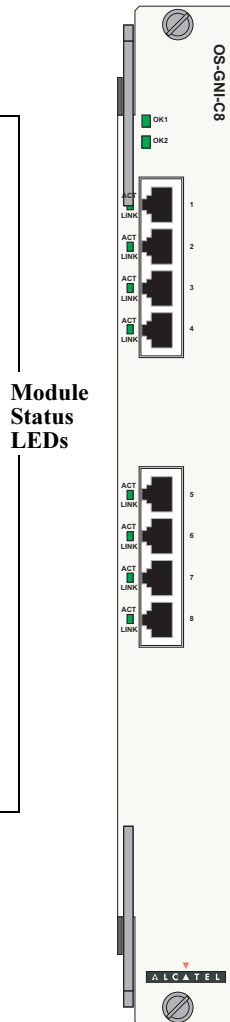

Module Status LEDs

Gigabit Ethernet Ports

The OS8-GNI-C8 module provides 8 Gigabit Ethernet ports. These ports are twisted-pair RJ-45.

Refer to the Technical Specifications table on [page 5-8](#) for more information.

OS8-GNI-C8 Front Panel

OS8-GNI-C8 Technical Specifications

Number of ports	8 twisted-pair
Connector type	RJ-45
Standards supported	802.3z, 802.3ab; 1000Base-T
Data rate	1 Gigabit per second (full duplex)
Maximum frame size	9216 bytes OS8-GNI-C8 modules support jumbo frames (1500 to 9000 bytes)
MAC addresses supported	32000 per Network Interface (NI) module
Connections supported	1000BaseT connection to backbone or server
Cable supported	1000BaseT: unshielded twisted-pair (UTP), Category 5e
Maximum cable distance	100 meters, Category 5
Current draw	5.96 amps at 24 volts
Power	143 watts (approximate)

OS8-GNI-U8 Front Panel

Module Status LEDs

OK1. Hardware Status. Displays solid green when powered on and the GNI has passed hardware diagnostic tests. Displays solid amber when powered on and the GNI has failed hardware diagnostic tests.

OK2. Software Status. Blinks green when the GNI is operational and has successfully loaded software. Displays solid amber when powered on and the GNI has failed to load software.

Gigabit Ethernet Port LEDs

ACT. Flashes green when data is transmitted or received on the corresponding Gigabit Ethernet port.

LINK. Link Integrity Status. Displays solid green when a fiber cable connection exists at the corresponding Gigabit Ethernet port.

Module Status LEDs

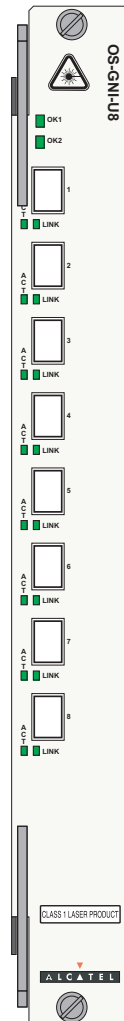

Gigabit Ethernet Ports

The OS8-GNI-U8 module provides 8 MiniGBIC slots. These slots support the following MiniGBIC types:

- MINIGBIC-SX—1000BaseSX Multimode fiber, supports distances up to 550 meters; uses LC connectors.
- MINIGBIC-LX—1000BaseLX Single mode fiber, supports distances up to 10 km; uses LC connectors.
- MINIGBIC-LH-70—1000BaseLH Long haul fiber, supports distances up to 70 km; uses LC connectors.

Note

See [page 5-35](#) for information on proper handling of LC connectors and fiber-optic cable.

OS8-GNI-U8 Front Panel

OS8-GNI-U8 Technical Specifications

Number of MiniGBIC ports	8 (hot-pluggable)
Connector types	LC
Standards supported	802.3z; 1000Base-SX, 1000Base-LX
Data rate	1 Gigabit per second (full duplex)
Maximum frame size	9216 bytes OS8-GNI-U8 modules support jumbo frames (1500 to 9000 bytes)
MAC addresses supported	32000 per Network Interface (NI) module
Connections supported	1000Base-SX, 1000Base-LX, or 1000Base-LH70 connection to backbone or server (fiber)
Fiber optic cable supported	Multimode and single mode
Output optical power	-9.5 to 0 dBm (multimode) -11 to -3 dBm (intermediate reach single mode) 0 to +5 dBm (long reach single mode)
Input optical power	-17 to 0 dBm (multimode) -19 to -3 dBm (intermediate reach single mode) -23 to -3 dBm (long reach single mode)
Cable distances ^a	Multimode fiber ≈ 220 m Intermediate reach single mode fiber ≈ 10 km Long reach single mode fiber ≈ 70 km
Current draw	5.63 amps at 24 volts
Power	135 watts (approximate)

a. Please note that distances are based on optimal conditions and may decrease depending on such factors as fiber diameter and quality.

Note. Connector and cable information in the above table is dependent on the type of MiniGBIC(s) installed in the OS8-GNI-U8 module. For a technical breakdown of each MiniGBIC type, refer to [“MiniGBIC Specifications” on page 5-13](#).

OS8-GNI-U24/OS8-GNI2-U24 Front Panel

Module Status LEDs

OK1. Hardware Status. Displays solid green when powered on and the GNI has passed hardware diagnostic tests. Displays solid amber when powered on and the GNI has failed hardware diagnostic tests.

OK2. Software Status. Blinks green when the GNI is operational and has successfully loaded software. Displays solid amber when powered on and the GNI has failed to load software.

Gigabit Ethernet Port LEDs

Each fiber-based Gigabit Ethernet port has a corresponding LED. This LED indicates the link and activity status for each Gigabit Ethernet port. The LED displays green when a valid Gigabit Ethernet cable connection exists. Flashes green as data is transmitted or received on the port.

Module Status LEDs

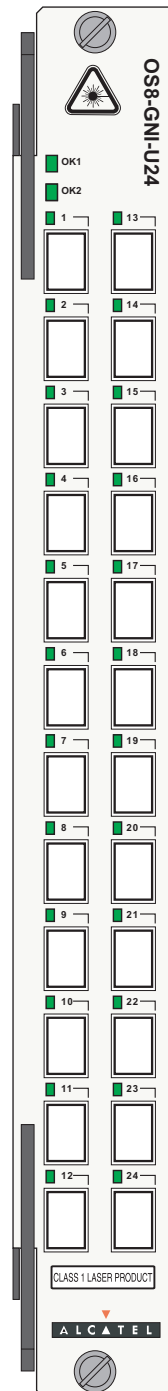

Module Label

The label on the front panel identifies the module type: either OS8-GNI-U24 or OS8-GNI2-U24.

Gigabit Ethernet Ports

The OS8-GNI-U24 and OS8-GNI2-U24 modules provide 24 MiniGBIC slots. These slots support the following MiniGBIC types:

- MINIGBIC-SX—1000BaseSX
Multimode fiber, supports distances up to 550 meters; uses LC connectors.
- MINIGBIC-LX—1000BaseLX
Single mode fiber, supports distances up to 10 km; uses LC connectors.
- MINIGBIC-LH-70—
1000BaseLH
Long haul fiber, supports distances up to 70 km; uses LC connectors.

OS8-GNI-U24 Front Panel

OS8-GNI-U24/OS8-GNI2-U24 Technical Specifications

Number of MiniGBIC ports	24 (hot-pluggable)
Connector types	LC
Standards supported	802.3z; 1000Base-SX, 1000Base-LX
Data rate	1 Gigabit per second (full duplex)
Maximum frame size	9216 bytes OS8-GNI-U24 modules support jumbo frames (1500 to 9000 bytes)
MAC addresses supported	32000 per Network Interface (NI) module
Connections supported	1000Base-SX, 1000Base-LX or 1000Base-LH70 connection supporting multiple uplinks from wire closet switches and supporting a large number of Gigabit backbone links in core applications.
Fiber optic cable supported	Multimode and single mode
Output optical power	-9.5 to 0 dBm (multimode) -11 to -3 dBm (intermediate reach single mode) 0 to +5 dBm (long reach single mode)
Input optical power	-17 to 0 dBm (multimode) -19 to -3 dBm (intermediate reach single mode) -23 to -3 dBm (long reach single mode)
Cable distances ^a	Multimode fiber ≈ 220 m Intermediate reach single mode fiber ≈ 10 km Long reach single mode fiber ≈ 70 km
Current draw	4.96 amps at 24 volts
Power	119 watts (approximate)

a. Please note that distances are based on optimal conditions and may decrease depending on such factors as fiber diameter and quality.

Note. Connector and cable information in the above table is dependent on the type of MiniGBIC(s) installed in the OS8-GNI-U24 or OS8-GNI2-U24 module. For a technical breakdown of each MiniGBIC type, refer to [“MiniGBIC Specifications” on page 5-13](#).

MiniGBIC Specifications

MINIGBIC-SX Technical Specifications

Connector type	LC
Standards supported	802.3z, 1000Base-SX
Connections supported	1000Base-SX connection to backbone or server
Fiber optic cable supported	Multimode
Wavelength	850 nm (typical)
Output optical power	-9.5 to 0 dBm
Input optical power	-17 to 0 dBm
Cable distances	≈ 220 m

MINIGBIC-LX Technical Specifications

Connector types	LC
Standards supported	802.3z, 1000Base-LX
Connections supported	1000Base-LX connection to backbone or server
Fiber optic cable supported	Single mode
Wavelength	1310 (typical)
Output optical power	-11 to -3 dBm
Input optical power	-19 to -3 dBm (intermediate reach single mode)
Cable distances	≈10 km

MINIGBIC-LH-70 Technical Specifications

Connector types	LC
Standards supported	802.3z
Connections supported	1000Base-LH70 connection to backbone or server
Fiber optic cable supported	Single mode
Wavelength	1550 nm (typical)
Output optical power	0 to +5 dBm
Input optical power	-23 to -3 dBm
Cable distances	Long reach single mode fiber ≈ 70 km

Installing MiniGBIC Connectors

If you are installing an OS8-GNI-U8 or OS8-GNI-U24 module, you must install Miniature Gigabit Interface Converters (MiniGBICs) as required. OS8-GNI-U8 modules provide ports for up to 8 MiniGBICs and OS8-GNI-U24 modules provide ports for up to 24 MiniGBICs. These MiniGBIC are packaged separately. To install a MiniGBIC follow the steps below.

Anti-Static Warning. Before handling any components, free yourself of static by wearing a grounding strap, or by grounding yourself properly. Static discharge can damage the MiniGBIC, as well as the switch and uplink module. Refer to [“Using the Grounding Wrist Strap and Chassis Grounding Lug” on page 5-29](#) for more information.

- 1 When inserting a MiniGBIC, be sure that the hinged face is closed.
- 2 Slide the MiniGBIC straight into the slot until the module clicks firmly into place.
- 3 Push the MiniGBIC into the slot until it clicks into place.

Note. The diagram below is a representation only; the physical appearance of the actual MiniGBIC may vary.

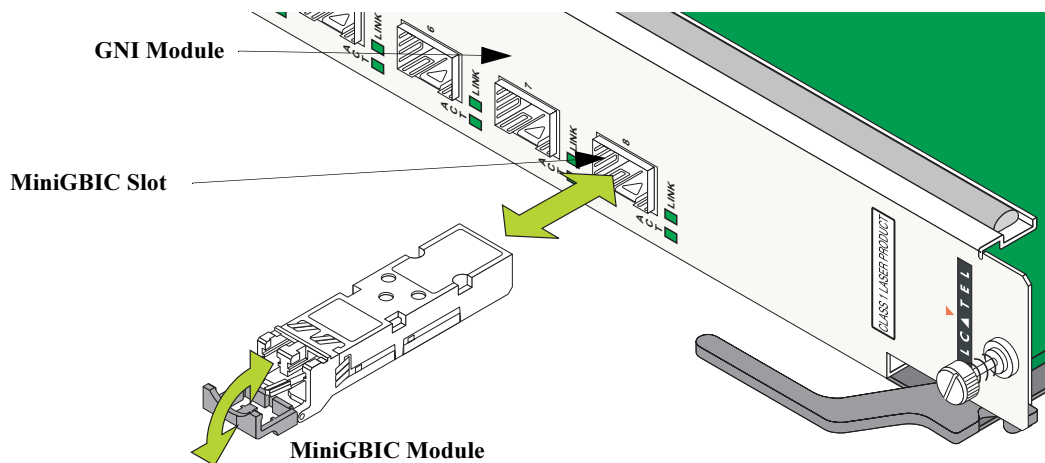

Caution. The MiniGBIC should slide in easily. Do not force it into the slot. If any resistance is encountered, ensure the MiniGBIC is aligned properly. Forcing the MiniGBIC into the slot can damage the unit, as well as components on your GNI module.

Note. To remove a MiniGBIC, you must first open the MiniGBIC's hinged face to approximately ninety degrees. Then, grasp the hinged face and carefully pull the MiniGBIC straight out of the slot.

Removing MiniGBIC Connectors

MiniGBICs modules can be hot swapped. You are not required to power off the switch before removing a MiniGBIC from an OS8-GNI-U8 or OS8-GNI-U24 module. To remove a Miniature Gigabit Interface Converter (MiniGBIC) follow the steps below.

Note. Before handling any components, free yourself of static by wearing a grounding strap, or by grounding yourself properly. Static discharge can damage the MiniGBIC, as well as the Gigabit Ethernet fiber module. Refer to [“Using the Grounding Wrist Strap and Chassis Grounding Lug” on page 5-29](#) for more information.

- 1 Remove any LC cables from the MiniGBIC.
- 2 To remove a MiniGBIC you must first open the MiniGBIC’s hinged face to approximately ninety degrees. Then, grasp the hinged face and carefully pull the MiniGBIC straight out of the slot

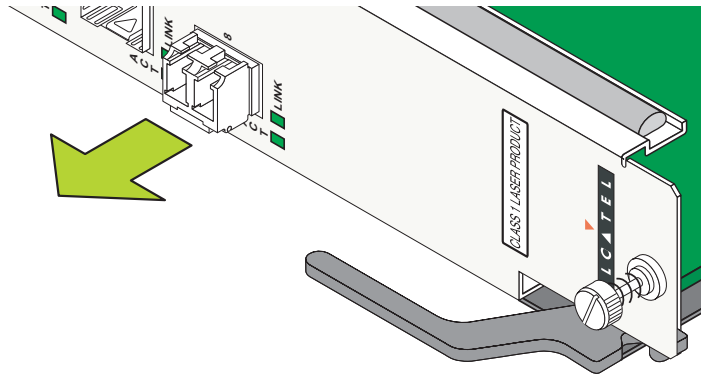

- 3 Slide the MiniGBIC out of the module’s port.
- 4 Store the MiniGBIC in a secure, static-free location. Placing the MiniGBIC in an anti-static bag is recommended.

OS8-GNI-C24/OS8-GNI2-C24 Front Panel

Module Status LEDs

OK1. Hardware Status. Displays solid green when powered on and the GNI has passed hardware diagnostic tests. Displays solid amber when powered on and the GNI has failed hardware diagnostic tests.

OK2. Software Status. Blinks green when the GNI is operational and has successfully loaded software. Displays solid amber when powered on and the GNI has failed to load software.

Module Status LEDs

Ethernet Port LEDs

Each Gigabit Ethernet port has two built-in corresponding LEDs. The top LED indicates 10/100 Mbps link and activity status for the port while the bottom LED indicates 1 Gigabit link and activity status for the port. The appropriate LED displays green when a valid Ethernet cable connection exists. Flashes green as data is transmitted or received on the port.

Refer to diagram on the bottom of the NI for locations of the two (10/100 or Gigabit) LEDs.

Module Status LEDs

Module Label

The label on the front panel identifies the module type: either OS8-GNI-C24 or OS8-GNI2-C24.

Ethernet Ports

The OS8-GNI-C24 and OS8-GNI2-C24 modules provide 24 10/100/1000 Ethernet ports. These ports are twisted-pair and are individually configurable as 10BaseT, 100BaseTX, or 1000BaseT. The ports use RJ-45 connectors.

Refer to the Technical Specifications table on [page 5-17](#) for more information.

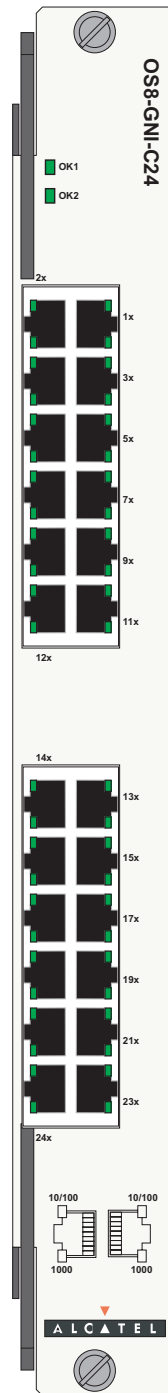

OS8-GNI-C24 Front Panel

OS8-GNI-C24/OS8-GNI2-C24 Technical Specifications

Number of ports	24 twisted-pair
Connector type	RJ-45
Standards supported	802.3z, 802.3ab; 1000Base-T
Data rate	10 or 100 Mbps (full or half duplex) 1 Gigabit per second (full duplex)
Maximum frame size	1533 bytes (10 or 100 Mbps) 9216 bytes (1 Gigabit) OS8-GNI-C24 modules support jumbo frames (1500 to 9000 bytes)
MAC addresses supported	32000 per Network Interface (NI) module
10 Mbps Connections supported	10BaseT hub or device
100 Mbps Connections supported	100BaseTX hub or device
1 Gigabit Connections supported	1000BaseT connection to backbone or server
10 Mbps Cable supported	10BaseT: unshielded twisted-pair (UTP)
100 Mbps Cable supported	100BaseTX: unshielded twisted-pair (UTP), Category 5, EIA/TIA 568 or shielded twisted-pair (STP), Category 5, 100 ohm
1 Gigabit Cable supported	1000BaseT: unshielded twisted-pair (UTP), Category 5e
Maximum cable distance	100 meters, Category 5
Current draw	4.58 amps at 24 volts
Power	110 watts (approximate)

10GNI Modules

OmniSwitch 8800 10 Gigabit Network Interface (10GNI) modules provide one redundant wire-rate 10000 Mbps (10 Gbps) connection per module. In addition, 10GNI modules can be used in enterprise applications including backbone connections in networks where 10 Gigabit Ethernet is used as the backbone media.

Like ENI and GNI modules, 10GNI modules are also supported during CMM failover. Refer to [“Smart Continuous Switching” on page 5-26](#) for details.

The following wire-rate 10 Gbps 10GNI module is available:

- **OS8-10GNI-UR1.** Provides two redundant Xenpak slots acting as one port. (Only one port can be active at a time.) Refer to [page 5-20](#) for detailed information on this module.

Xenpaks are 10 Gigabit Ethernet port modules that are hot-pluggable—i.e., they can be installed or removed while the 10GNI is powered on and operating without the risk of damage to the Xenpak module or the host circuitry. Alcatel Xenpaks are MSA (Multi Source Agreement) compliant. For information on Xenpaks, refer to [page 5-23](#).

Three Xenpak types are available for OS8-10GNI-UR1 modules:

- **OM-10GNI-SR**— 10GBASE-S multimode 850 nanometers (nm) fiber with a serial (one color of wavelength) transceiver, supports distances up to 300 meters¹ over multimode fiber; uses SC connectors
- **OM-10GNI-LR**— 10GBASE-L single mode 1310 nm fiber with a serial transceiver, supports distances up to 10 km over single mode fiber; uses SC connectors
- **OM-10GNI-ER**— 10GBASE-E single mode 1550 nm fiber with a serial transceiver, supports distances up to 40 km over single mode fiber; uses SC connectors.

Although only one Xenpak module is necessary, you must install two Xenpak modules (one in each slot) in order to achieve redundancy. See [“OS8-10GNI-UR1 Port Redundancy” on page 5-19](#) for more information.

Note. You can install different Xenpak types on the same OS8-10GNI-UR1 module.

See [“Handling Fiber and Fiber Optic Connectors” on page 5-35](#) for proper handling of SC connectors and fiber-optic cable.

¹ High modal bandwidth fiber is required to reach 300 meters.

OS8-10GNI-UR1 Port Redundancy

In the event of a failure the primary port (labeled **1** on the front panel), the 10GNI module will automatically switch over to the secondary port (labeled **2** on the front panel). No user intervention is required. Please note that one port can be active at one time.

To force port 1 (PHY-A) or port 2 (PHY-B) as the primary (active) port, use the **10gig slot** command by entering 10gig slot followed by the slot number and either phy-a or phy-b.

For example, to configure port 2 (PHY-B) as the active port on the OS8-10GNI-UR1 module in slot 9 enter:

```
-> 10gig slot 10 phy-b
```

To confirm which port is the active one refer to the LEDs on the front panel (see [“OS8-10GNI-UR1 Front Panel” on page 5-20](#) for information) or use the **show 10gig** command as shown below:

```
-> show 10gig slot 10  
Slot 10: PHY B primary
```

Unsupported Software Features

The OS8-10GNI-UR1 is intended for core application and does not support some user applications. The following is a list of software features that are not supported on the OS8-10GNI-UR1 in the current release:

- Group mobility
- Authenticated VLANs (AVLANs)
- Link aggregation
- Learned Port Security (LPS)
- Port mirroring
- Hardware-based multicast routing
- High-availability VLANs

OS8-10GNI-UR1 Front Panel

Module Status LEDs

OK1. Hardware Status. Displays solid green when powered on and the 10GNI has passed hardware diagnostic tests. Displays solid amber when powered on and the 10GNI has failed hardware diagnostic tests.

OK2. Software Status. Blinks green when the 10GNI is operational and has successfully loaded software. Displays solid amber when powered on and the 10GNI has failed to load software.

Gigabit Ethernet Port LEDs

The OS8-10GNI-UR1 provides the following LEDs for each Xenpak slot:

Tx. Transmit Status. On the active port this will LED will blink green when it is transmitting data. On the inactive port this LED will always be off.

Rx. Receive Status. On the active port this will LED will blink green when it is receiving data. On the inactive port this LED will always be off.

Link. Link Status. This LED will be solid green if there is a Xenpak module plugged into the port.

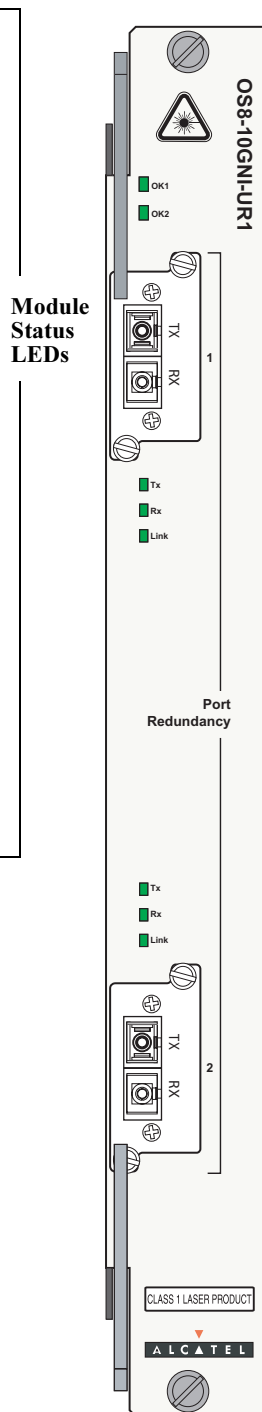

Module Status LEDs

10 Gigabit Ethernet Ports

The OS8-10GNI-UR1 module provides 2 Xenpak slots, which act as one redundant port. These slots support the following Xenpak types:

- OM-10GNI-SR—10GBASE-S Multimode fiber, supports distances up to 300 meters; uses SC connectors.
- OM-10GNI-LR—10GBASE-L Single mode fiber, supports distances up to 10 km; uses SC connectors.
- OM-10GNI-ER—10GBASE-E Long-haul single mode fiber, supports distances up to 40 km; uses SC connectors.

OS8-10GNI-UR1 Front Panel

OS8-10GNI-UR1 Technical Specifications

Number of Xenpak slots	2 slots acting as one redundant port
Connector types	SC
Standards supported	IEEE 802.3ae 10 Gigabit Ethernet
Data rate	10 Gigabits per second (full duplex)
Maximum frame size	9212 bytes OS8-10GNI-UR1 modules support 2048, 4096, 8192, and 9212 jumbo frame sizes
MAC addresses supported	32000 per Network Interface (NI) module
Connections supported	10GBASE-S, 10GBASE-L, and 10GBASE-E over LAN Phy.
Fiber optic cables supported	Multimode (62.5 and 50 micron) and single mode
Power budget	OM-10GNI-SR: 7.3 dB OM-10GNI-LR: 9.4 dB OM-10GNI-ER: 15.0 dB
Output optical power	OM-10GNI-SR: -7.3 dBm (minimum) OM-10GNI-LR: -8.2 to 0.5 dBm OM-10GNI-ER: -4.7 to 4.0 dBm
Input optical power	OM-10GNI-SR: -9.9 to -1.0 dBm OM-10GNI-LR: -14.4 to 0.5 dBm OM-10GNI-ER: -15.8 to -1.0 dBm
Cable distances ^a	OM-10GNI-SR: 300 m (high modal bandwidth fiber is required to reach 300 meters) OM-10GNI-LR: 10 km OM-10GNI-ER: 40 km
Current draw	4.58 amps at 24 volts
Power	110 watts (approximate)

a. Please note that distances are based on optimal conditions and may decrease depending on such factors as fiber diameter and quality.

Note. Connector and cable information in the above table is dependent on the type of Xenpak(s) installed in the OS8-10GNI-UR1 module. For a technical breakdown of each Xenpak type, refer to [“Xenpak Specifications” on page 5-22](#).

Xenpak Specifications

OM-10GNI-SR Technical Specifications

Connector type	SC
Standards supported	IEEE 802.3ae
Connections supported	10GBASE-S over multimode fiber
Fiber optic cable supported	Multimode
Transceiver type	Serial
Wavelength	850 nm (typical)
Power budget	7.3 dB
Output optical power	-7.3 dBm (minimum)
Input optical power	-9.9 to -1.0 dBm
Cable distances	≈ 300 m (high modal bandwidth fiber is required to reach 300 meters)

OM-10GNI-LR Technical Specifications

Connector types	SC
Standards supported	IEEE 802.3ae
Connections supported	10GBASE-L over single mode fiber
Fiber optic cable supported	Single mode
Transceiver type	Serial
Wavelength	1310 (typical)
Power budget	9.4 dB
Output optical power	-8.2 to 0.5 dBm
Input optical power	-14.4 to 0.5 dBm (intermediate reach single mode)
Cable distances	≈10 km

OM-10GNI-ER Technical Specifications

Connector types	SC
Standards supported	IEEE 802.3ae
Connections supported	10GBASE-E over single mode fiber
Fiber optic cable supported	Single mode
Transceiver type	Serial
Wavelength	1550 nm (typical)
Power budget	15.0 dB
Output optical power	-4.7 to 4.0 dBm
Input optical power	-15.8 to -1.0 dBm
Cable distances	≈ 40 km

Installing Xenpak Connectors

If you are installing an OS8-10GNI-UR1 module, you must install Xenpaks as required. Alcatel OS8-10GNI-UR1 modules provide slots for up to 2 Xenpak submodules, which act as a single 10 Gigabit port. These Xenpaks are packaged separately. To install a Xenpak follow the steps below.

Anti-Static Warning. Before handling any components, free yourself of static by wearing a grounding strap, or by grounding yourself properly. Static discharge can damage the Xenpak, as well as the switch and uplink module. Refer to [“Using the Grounding Wrist Strap and Chassis Grounding Lug” on page 5-29](#) for more information.

- 1 Remove the blank slot cover plate from the OS8-10GNI-UR1’s front face and set the cover plate and screws aside.
- 2 Align the groove on the Xenpak module with the guide rails on the OS8-10GNI-UR1’s circuit board as shown below:

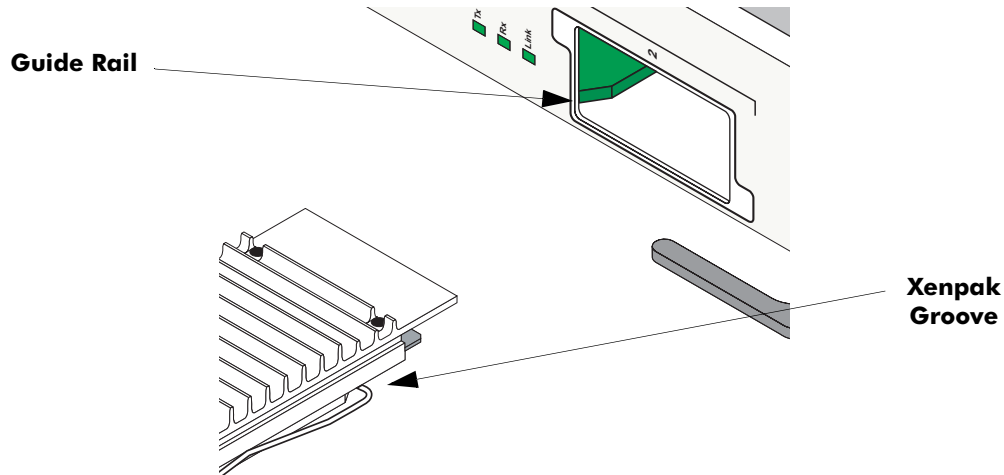

Note. The diagram above is a representation only; the physical appearance of the actual Xenpak may vary.

- 3 Slide the Xenpak straight into the slot until the module clicks firmly into place.

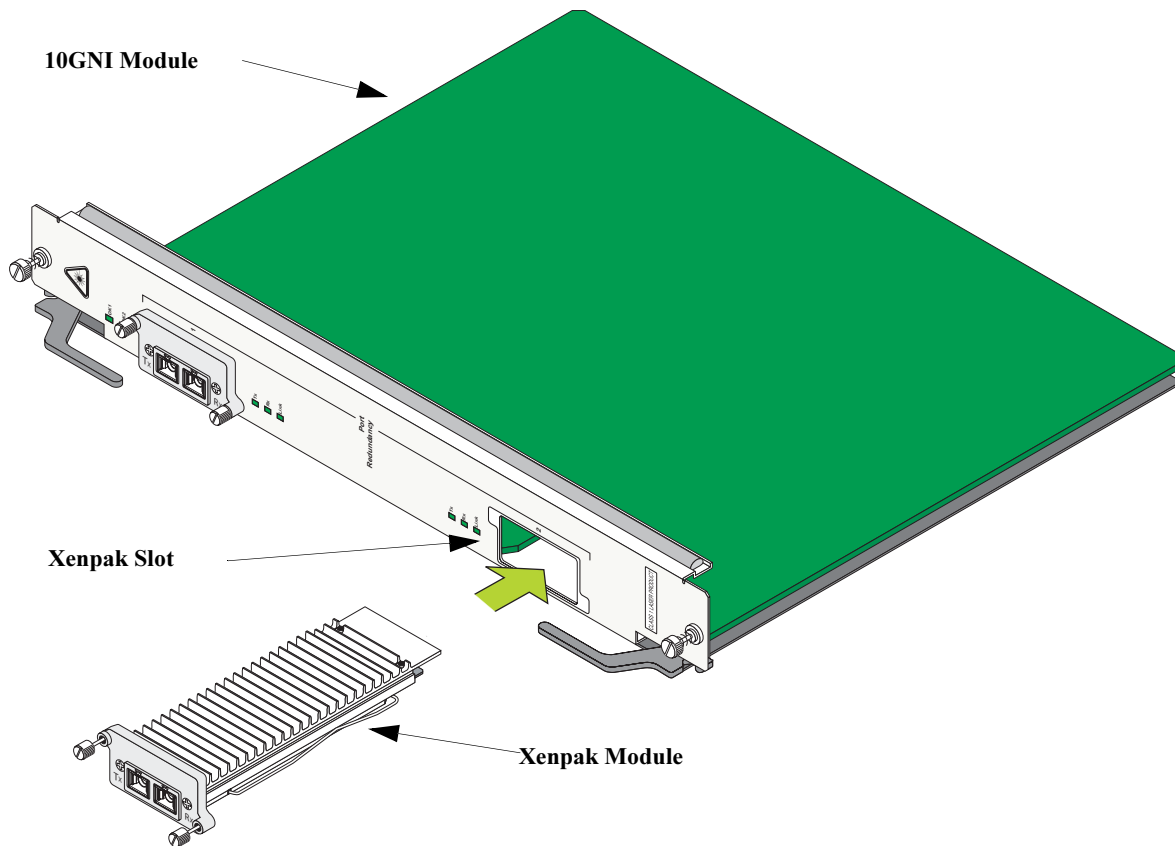

Caution. The Xenpak should slide in easily. Do not force it into the slot. If any resistance is encountered, ensure the Xenpak is aligned properly. Forcing the Xenpak into the slot can damage the unit, as well as components on your 10GNI module.

- 4 Tighten the two captive screws by turning them clockwise. *Be sure not to overtighten the captive screws. If you use a screwdriver, the torque used to tighten the screws must not exceed 2.3 inch pounds.*

Removing Xenpak Connectors

Xenpaks modules can be hot swapped. You are not required to power off the switch before removing a Xenpak from an OS8-10GNI-UR1 module. To remove a Xenpak follow the steps below.

Note. Before handling any components, free yourself of static by wearing a grounding strap, or by grounding yourself properly. Static discharge can damage the Xenpak, as well as the Gigabit Ethernet fiber module. Refer to [“Using the Grounding Wrist Strap and Chassis Grounding Lug” on page 5-29](#) for more information.

- 1 Remove any SC cables from the Xenpak.
- 2 Untighten the two captive screws by turn them counterclockwise.
- 3 Slide the Xenpak out of the module’s port.

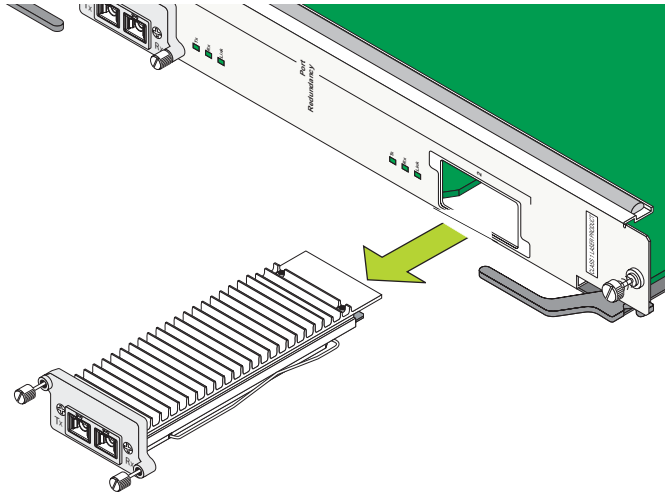

- 4 Store the Xenpak in a secure, static-free location. Placing the Xenpak in an anti-static bag is recommended.

Note. If you do not replace the Xenpak module with another one attach the blank slot cover plate to the OS8-10GNI-UR1’s front face with the screws supplied with your NI module.

Smart Continuous Switching

In redundant CMM configurations, the switch provides support for NIs during failover. In other words, if the primary CMM fails or goes offline for any reason, NI modules will continue data transmission and routing functions during the secondary CMM's takeover process. This Availability feature is referred to as *Smart Continuous Switching*.

Incoming Layer 2 packets will continue to be sent to the appropriate egress port during failover. Known routes will also be supported. (Note, however, that the NI cannot learn new routes without CMM support. Any new route information will be ignored.) Spanning Tree will continue handling BPDUs received on the switch ports, as well as port link up and down states. The Spanning Tree topology will not be disrupted.

Note. Smart Continuous Switching is designed to maintain traffic flow only during CMM failover and is *not* intended to support long-term traffic flow. If both the primary and redundant CMMs go offline or are removed from the chassis, switch operations (including all NI support) will be disabled.

Module Priorities During Boot Sequence

During the power checking sequence, CMMs receive priority and are always powered on. NI modules are then powered on sequentially by slot position. In other words, the NI in slot 1 is powered on, then slot 2, then slot 3, etc. For information on slot positions, refer to [Chapter 2, “Chassis and Power Supplies.”](#)

Managing NI Modules

Turning Power On or Off for a Specific NI Module

The CLI allows you to power on or power off specific NI modules. To turn the power off for a specific NI module, use the **no** form of the **power ni** command. Be sure to specify the syntax **no**, along with the slot number of the NI. For example:

```
-> no power ni slot 3
```

To return power to a specific NI module, use the **power ni** command. Be sure to specify the slot number of the NI in the command line. For example:

```
-> power ni slot 3
```

Individual NI Reload

Each NI installed in the switch can be reloaded on an individual basis. A reload is essentially a soft boot of the NI module. When an individual NI is reloaded, only the specified NI is affected. All other NIs installed in the switch continue operating without interruption. To reload a specific NI module, use the **reload ni** command. Be sure to specify the slot number of the NI in the command line. For example:

```
-> reload ni 3
```

For detailed information on the **no power ni**, **power ni**, and **reload ni** commands, refer to the “Chassis Management and Monitoring Commands” chapter in the *OmniSwitch CLI Reference Guide*.

Monitoring NI Modules

Front Panel LEDs

All NIs provide a series of status LEDs located on the front panel. These LEDs offer basic status information for the following functions:

- NI hardware operation
- NI software status
- Port link and activity status

Pages 5-4 through 5-16 provide detailed LED information for ENI and GNI modules, respectively.

Accessing General NI Information

The switch's Command Line Interface (CLI) offers NI monitoring commands. These commands allow you to access general NI hardware information as well as the current operating status.

To access general NI information, use the **show ni** command. For example:

```
-> show ni 3
Module in slot 3
  Model Name:           OS8-ENI-C24 ,
  Description:         24pt 10/100 Mod,
  Part Number:         901765-10,
  Hardware Revision:   405,
  Serial Number:       1463265A,
  Manufacture Date:    DEC 18 2001,
  Firmware Version:    5,
  Admin Status:        POWER ON,
  Operational Status:  UP,
  Power Control Checksum: 0x732,
  MAC Address:         00:d0:95:6a:7f:ce,
  ASIC - Physical:     0x1901 0x0201 0x0201 0x001e 0x001e 0x001e
```

For more information about this display and other NI monitoring commands, see the “Chassis Management and Monitoring Commands” chapter in the *OmniSwitch CLI Reference Guide*.

Hot Swapping NI Modules

You are not required to enter a CLI command in order to hot swap NI modules. The hot swap function can be performed on the fly by simply removing the module from the switch chassis. For information on properly removing modules, refer to [“Removing a Module” on page 5-30](#).

Module Presence Signalling

On-the-fly module removal is provided through the presence signalling function. All modules in the switch send out “presence signals.” When a module sends out this signal, it is essentially advertising to all other modules in the switch that it is present in the chassis. When a module is present, information such as its module type (primary CMM, secondary CMM, SFM, ENI, or GNI) becomes available for monitoring functions.

The presence signal is controlled through a shortened connector pin that interfaces with the switch’s backplane. Because this connector pin is shorter than the module’s other backplane connectors, the presence signal connection is the first to become interrupted when a board is removed from the chassis. This allows the switch additional time (approximately 5 ms) to complete the current transfer of data before the module is completely disconnected. (In order to avoid data loss, the switch immediately stops incoming traffic and flushes outgoing traffic on the module being removed.)

Note. Although presence signalling is designed to maintain data flow on the switch during the hot swap procedure, uninterrupted data flow cannot be guaranteed. As a result, you should not hot swap CMM or NI modules during critical network activity.

Removing and Adding Modules

Using the Grounding Wrist Strap and Chassis Grounding Lug

Because electrostatic discharge (ESD) can damage switch components such as the Network Interface (NI) and Chassis Management Modules (CMMs), you must always ground yourself properly before removing or adding a module. For this purpose, Alcatel provides a grounding wrist strap and a grounding lug located near the bottom-right of the chassis. To properly ground yourself, follow the steps below.

- 1 Fasten the grounding strap to your wrist. (A grounding strap was provided in your OmniSwitch 8800 ship kit.)
- 2 Insert the wrist strap's connector pin (located at the end of the strap's tether) into the grounding lug near the bottom-right of the chassis, as shown.

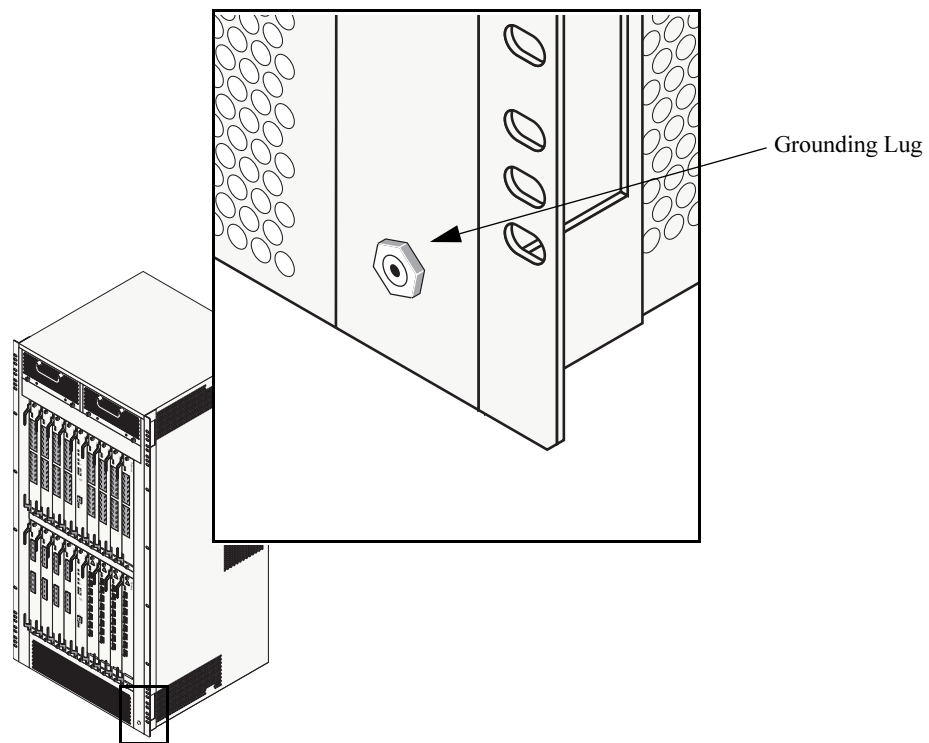

Note. For the grounding wrist strap to be effective in eliminating ESD, power supplies must be installed in the chassis and plugged into grounded AC outlets.

Module Types and Slot Positions

When installing modules in the chassis, consider the following:

- NI modules may be installed in any slot position from 1 through 16.
- CMMs may be installed in slots A or B.
- NI modules cannot be installed in CMM slots A or B; likewise, CMMs cannot be installed in any NI slot position.
- At least four (4) SFMs must be installed in SFM slots 1 through 5 on the back of the chassis. (You can install SFMs in all five slots for redundancy.)

More Information on Slot Numbering. For a diagram showing the chassis layout and slot positions, refer to [Chapter 2, “Chassis and Power Supplies.”](#)

Removing a Module

To remove a CMM or NI module from the chassis, follow the steps below.

Note. To remove an SFM, see [Chapter 4, “Switch Fabric Module \(SFM\).”](#)

1 First, loosen the module’s two captive screws that secure the module to the chassis. If necessary, use a flat-blade screwdriver to loosen the screws. Be sure that both captive screws are completely disengaged from the threaded holes in the chassis before continuing.

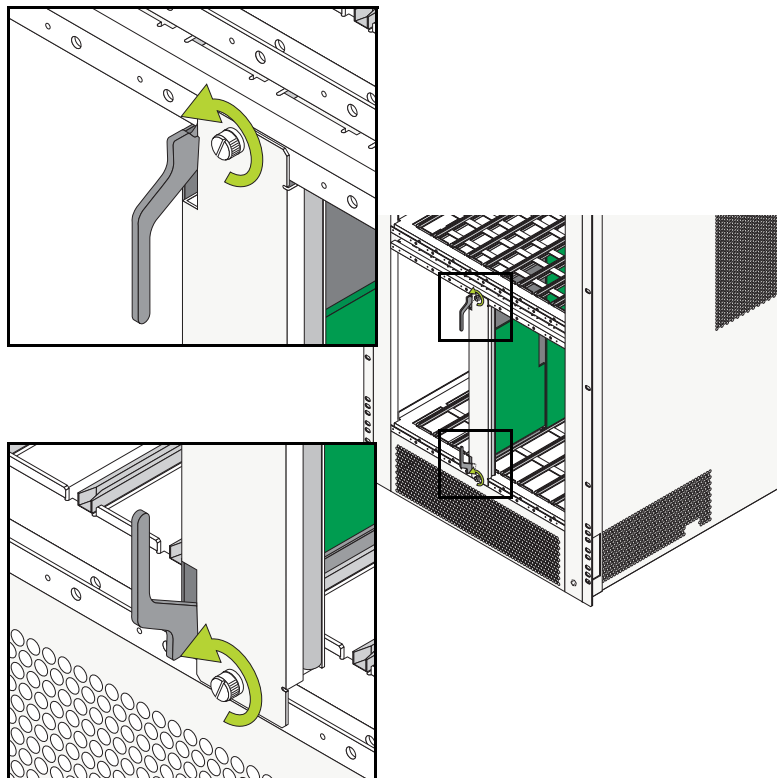

2 Next, simultaneously pull the two module extractor levers—one on top of the module and one on the bottom—until the module disengages from the chassis.

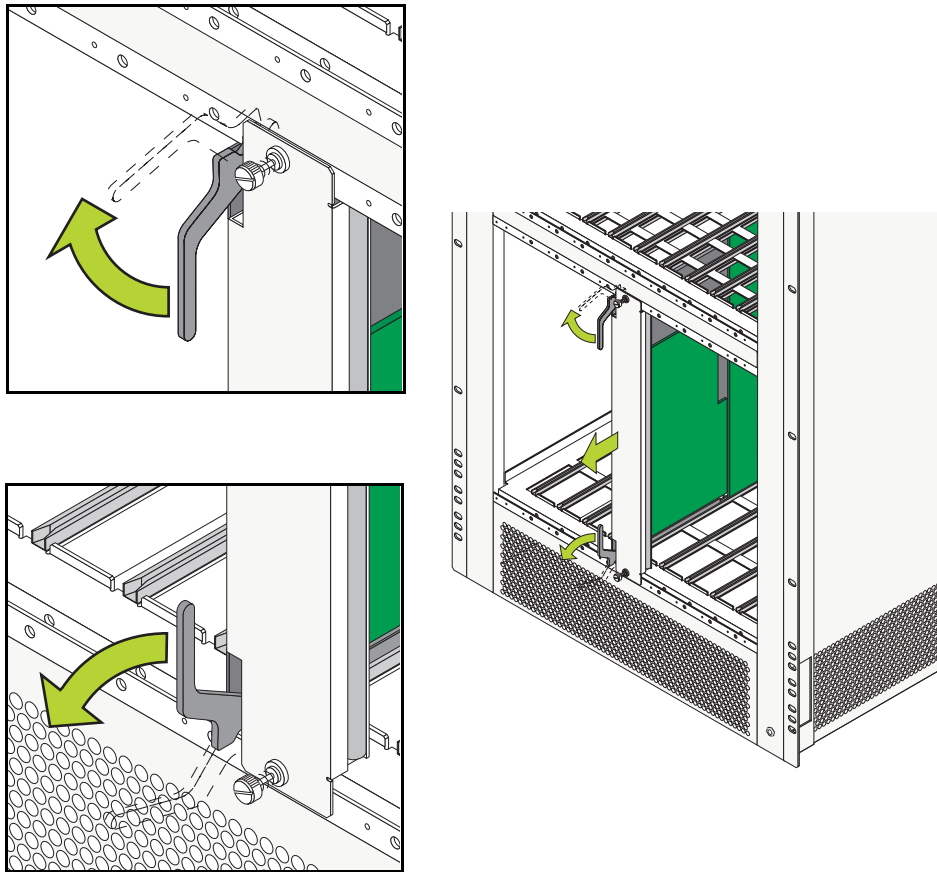

3 Holding the module in both hands, carefully slide it out of the chassis along the card guide. The module should slide out easily. Do not force the module from the slot.

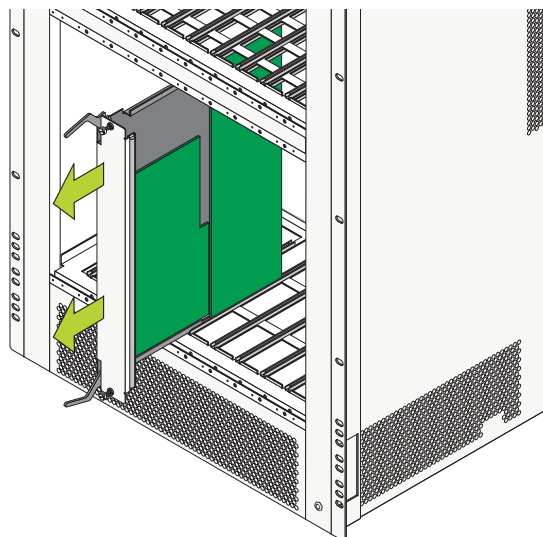

Adding a Module

To install a CMM or NI module, follow the steps below. (To remove an SFM, see [Chapter 4, “Switch Fabric Module \(SFM\)”](#)).

Important. Before beginning, note that the CMM modules and NI modules slide into the chassis card guides differently. With CMMs, the back of the module’s printed circuit board (which is wider than the front side) initially provides the glide path. When the printed circuit board narrows a sheet metal flange continues the remaining glide path. With NIs, the edges of the module’s printed circuit slide into the guides.

- 1 Holding the module in both hands, carefully slide it into the chassis card guide. The component side of the board should face right.

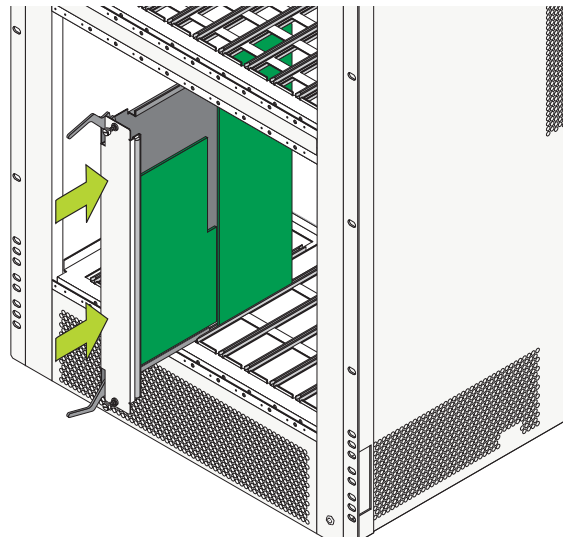

- 2 The module should slide in easily. Do not force the module into the slot. If any resistance is encountered, ensure the module is aligned properly in the card guide. Also, see the important note regarding chassis card guides on [page 5-32](#).

3 When the module is nearly seated in the slot, be sure that the two extractor levers—one on top of the module and one on the bottom—are slightly opened (approximately 30 degrees). This allows the notch on each extractor lever to grasp the rail on the chassis. Once the notches have grasped the rail, press both extractor levers inward simultaneously until the module is firmly seated.

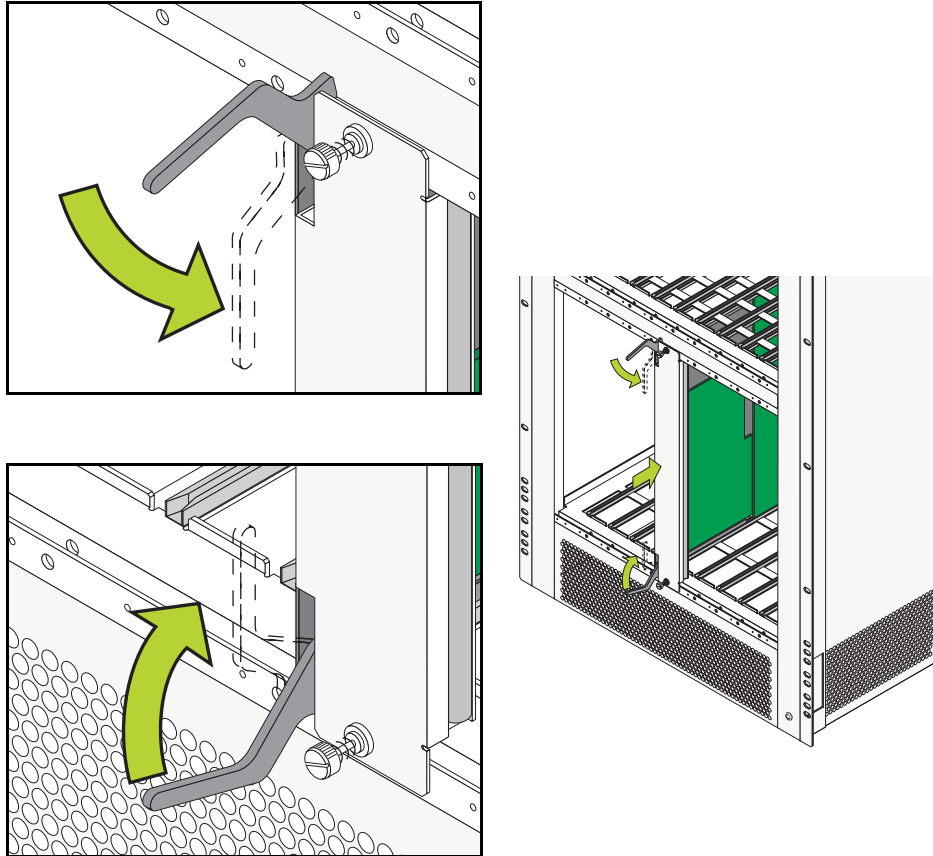

4 Once the module is firmly seated, secure the module to the chassis by tightening the two captive screws. *Be sure not to overtighten the captive screws. If you use a screwdriver, the torque used to tighten the screws must not exceed 2.3 inch pounds.*

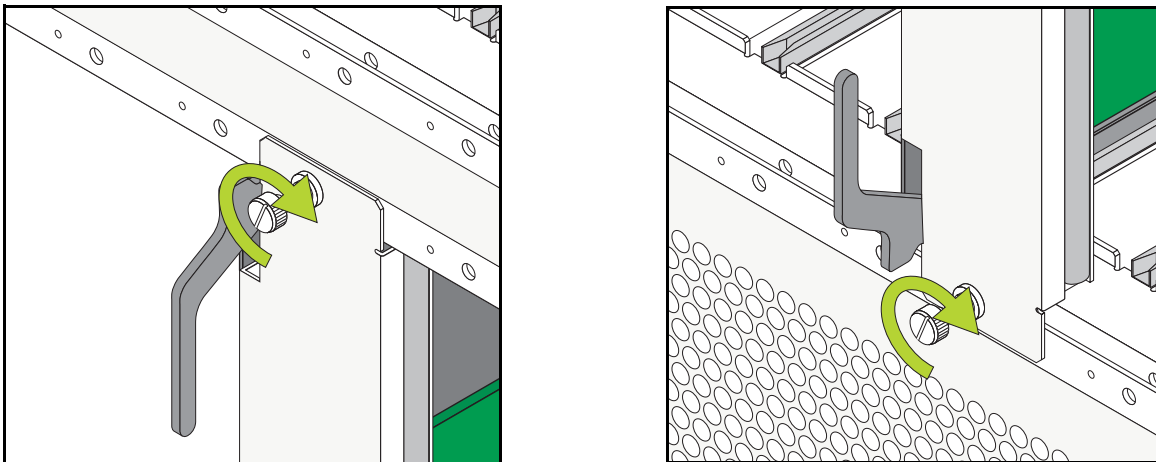

Pinouts

10/100 Ethernet Port – RJ-45 Pinout

Pin Number	Description
1	RX+
2	RX-
3	TX+
4	not used
5	not used
6	TX-
7	not used
8	not used

Gigabit Ethernet Port – RJ-45 Pinout

Pin Number	Description
1	BI_DB+
2	BI_DB-
3	BI_DA+
4	BI_DD+
5	BI_DD-
6	BI_DA-
7	BI_DC+
8	BI_DC-

Handling Fiber and Fiber Optic Connectors

Using fiber is extremely simple, but several important standards should always be practiced. For best results, you should:

- Use premium grade jumper cables with duplex LC connectors
- Keep your fiber optic connectors clean
- Keep the transceiver interface clean
- Attenuate properly

For detailed information on these recommendations, refer to the sections below.

Use Premium Grade Jumper Cables with Duplex LC Connectors

There are many brands of fiber optic jumper cables, with a wide range of quality between each manufacturer. Premium cables do three things well:

- They provide a good polish on the fiber optic connector endface (where the light exits the cable). Endface geometries must be exceptionally precise and aligned to extremely tight tolerances. The better the endface geometry, the lower the loss and more consistent the connection. Poor connector interfaces will reflect light back into the laser, causing an increase in laser noise.
- They mate well with other connector interfaces. Chances are the manufacturer of the jumper cable will not be the same as the manufacturer of the transceiver connector interface. Premium jumper cables mechanically align themselves well into most transceiver interfaces. This provides both better performance as well as better repeatability. You will always see a variance in transceiver power due to connector alignment, often as much as 0.3 to 0.7 dB. Good jumper cables help reduce this variance.
- They continue to mate well after many insertions and removals. Premium grade jumper use premium connectors that maintain their mechanical integrity up to and beyond 2000 insertion cycles.

For better repeatability, always use duplex (two connectors fused together and terminated to two cables) LC connectors on your jumper cables when connecting to a fiber-optic transceiver. Two simplex connectors inserted into a transceiver interface will often have up to 3 dB greater variation in repeatability compared to duplex connectors.

Never bend the fiber optic cable beyond its recommended minimum bend radius. This introduces bend losses and reflections that will degrade the performance of your system. It can also damage the fiber, although fiber is much tougher than most would assume. Still, it is highly recommended to buy only jumper cables with 3mm Kevlar jacketing, which offer superior protection and longer life.

Keep Your Fiber Optic Connectors Clean

Unlike electrical connectors, fiber-optic connectors must be extremely clean in order to ensure optimum system performance. Microscopic particles such as dust on the connector endface (i.e., where the light exits the connector) can degrade the performance of your system, often to the point of failure.

If you have low-power output from a fiber-optic transceiver or a fault signal from your equipment, begin the troubleshooting process by cleaning your fiber-optic connectors per manufacturer recommendations.

Keep the Transceiver Interface Clean

If you have cleaned your connectors, but still experience low-power output from a fiber-optic transceiver or a fault signal from your equipment, you should clean the transceiver interface by blowing inert dusting gas inside the transceiver interface. This removes dust and other small particles that may block the optical path between the optics of the transceiver and the connector's endface.

Attenuate Properly

Often, equipment using laser-based transceivers need to have the optical path attenuated when performing loop-back testing or testing between two pieces of equipment. Too much optical power launched into the receiver will cause saturation and result in system failure. If you are using single mode fiber and you do not know the power output of the laser, it is always best to use a 10 dB attenuator when testing. Using the wrong type of attenuator will introduce problems, most notably reflection of light back into the laser, often resulting in excess noise and causing system failure.

Inline attenuators eliminate the need for additional jumper cables and thus reduce the number of connection interfaces. This increases the integrity of the optical path resulting in a more accurate test.

A Regulatory Compliance and Safety Information

This appendix provides information on regulatory agency compliance and safety for the OmniSwitch 8800.

Declaration of Conformity: CE Mark

This equipment is in compliance with the essential requirements and other provisions of Directive 73/23/EEC and 89/336/EEC as amended by Directive 93/68/EEC.

Français: Ce matériel est conformément aux conditions essentielles et à d'autres dispositions de 73/23/EEC et de 89/336/EEC directifs comme modifié par Directive 93/68/EEC.

Deutsch: Diese Ausrüstung ist gemäß den wesentlichen Anforderungen und anderen Bestimmungen richtungweisenden 73/23/EEC und des 89/336/EEC, wie von Directive 93/68/EEC geändert.

Español: Este directivo equipo está en conformidad con los requisitos esenciales y otras provisiones 73/23/EEC y 89/336/EEC según la enmienda prevista por Directive 93/68/EEC.

Standards Compliance

The product bears the CE mark. In addition it is in compliance with the following other safety and EMC standards:

Safety Standards

- UL 60950
- CAN/CSA-C22.2 No. 60950-00
- EN 60950
- IEC 60950
- TS 001
- AS/NZS 3260
- CB Certification PBR IEC 950

EMC Standards

- FCC Part 15 (CFR 47) Class A/Class B
- ICES-003 Class A/Class B
- EN 55022 Class A/Class B
- CISPR 22 Class A/Class B
- AS/NZS 3548 Class A/Class B
- VCCI Class A/Class B
- EN 55024
- EN 50082-1
- EN 61000-3-2
- EN 61000-3-3
- EN 61000-4-2
- EN 61000-4-3
- EN 61000-4-4
- EN 61000-4-5
- EN 61000-4-6
- EN 61000-4-8
- ENC 1000-4-11

Safety and Environmental Standards

- ETS 300 019 Storage Class 1.1
- ETS 300 019 Transportation Class 2.3
- ETS 300 019 Stationary Use Class 3.1

All hardware switching modules used in an OmniSwitch 8800 comply with Class A and Class B standards for digital devices per the FCC Part 15, ICES-003, EN 55022, CISPR 22, AS/NZS 3548, and VCCI standards. Modules with copper connectors meet Class A requirements using unshielded (UTP) cables, but meet Class B requirements using shielded (STP) cables.

FCC Class A, Part 15

This equipment has been tested and found to comply with the limits for Class A digital device pursuant to Part 15 of the FCC Rules. These limits are designed to provide reasonable protection against harmful interference when the equipment is operated in a commercial environment. This equipment generates, uses, and can radiate radio frequency energy and, if not installed and used in accordance with the instructions in this guide, may cause interference to radio communications. Operation of this equipment in a residential area is likely to cause interference, in which case the user will be required to correct the interference at his own expense.

The user is cautioned that changes and modifications made to the equipment without approval of the manufacturer could void the user's authority to operate this equipment. It is suggested that the user use only shielded and grounded cables to ensure compliance with FCC Rules.

If this equipment does cause interference to radio or television reception, the user is encouraged to try to correct the interference by one or more of the following measures:

- Reorient the receiving antenna.
- Relocate the equipment with respect to the receiver.
- Move the equipment away from the receiver.
- Plug the equipment into a different outlet so that equipment and receiver are on different branch circuits.

If necessary, the user should consult the dealer or an experienced radio/television technician for additional suggestions.

Canada Class A Statement

This equipment does not exceed Class A limits per radio noise emissions for digital apparatus, set out in the Radio Interference Regulation of the Canadian Department of Communications.

Avis de conformité aux normes du ministère des Communications du Canada

Cet équipement ne dépasse pas les limites de Classe A d'émission de bruits radioélectriques pour les appareils numériques, telles que prescrites par le Règlement sur le brouillage radioélectrique établi par le ministère des Communications du Canada.

JATE

This equipment meets the requirements of the Japan Approvals Institute of Telecommunications Equipment (JATE).

CISPR22 Class A warning

This is a Class A product. In a domestic environment, this product may cause radio interference. Under such circumstances, the user may be requested to take appropriate countermeasures.

VCCI

This is a Class A product based on the standard of the Voluntary Control Council for Interference by Information Technology Equipment (VCCI). If this equipment is used in a domestic environment, radio disturbance may arise. When such trouble occurs, the user may be required to take corrective actions.

この装置は、情報処理装置等電波障害自主規制協議会（VCCI）の基準に基づくクラスA情報技術装置です。この装置を家庭環境で使用すると電波妨害を引き起こすことがあります。この場合には使用者が適切な対策を講ずるよう要求されることがあります。

Class A Warning for Taiwan and Other Chinese Markets

This is a Class A Information Product. When used in a residential environment, it may cause radio frequency interference. Under such circumstances, the user may be requested to take appropriate counter-measure.

警告使用者：
這是甲類的資訊產品，在居住的環境中使用時，可能會造成射頻干擾，在這種情況下，使用者會被要求採取某些適當的對策。

Translated Safety Warnings

Chassis Lifting Warning

Two people are required when lifting the chassis. Due to its weight, lifting the chassis unassisted can cause personal injury. Also be sure to bend your knees and keep your back straight when assisting with the lifting of the chassis.

Français: Deux personnes sont priées en soulevant le châssis. En raison de son poids, le levage du châssis sans aide peut causer injury. Also personnel soit sûr de déplier vos genoux et de garder votre arrière directement en assistant le levage du châssis.

Deutsch: Zwei Leute werden benoetigt, wenn man das Chassis anhebt. Wegen seines Gewichts, kann das Anheben des Chassis Personenschäden unassisted verursachen. Seien Sie auch sicher, Ihre Knie zu verbiegen und Ihr rückseitiges gerade zu halten bei der Unterstützung mit dem Anheben des Chassis.

Español: Requieren a dos personas al levantar el chasis. debido a su peso, la elevación del chasis puede causar sin ayuda daños corporales. También sea seguro doblar sus rodillas y guardar su posterior derecho al asistir con la elevación del chasis.

Blank Panels Warning

Because they regulate airflow and help protect internal chassis components, blank cover plates should remain installed at empty module slots and power supply bays at all times.

Français: Puisqu'ils règlent le flux d'air et aident à protéger les composants internes de châssis, les couvercles blanc devraient rester installés aux fentes vides de module et l'alimentation d'énergie aboie à tout moment.

Deutsch: Weil sie Luftstrom regeln und helfen, interne Chassisbestandteile zu schützen, sollten unbelegte Deckplatten installiert an den leeren Modulschlitzten bleiben und Spg.Versorgungsteil bellt ständig.

Español: Porque regulan la circulación de aire y ayudan a proteger componentes internos del chasis, las tapaderas en blanco deben seguir instaladas en las ranuras vacías del módulo y la fuente de alimentación ladra siempre.

Electrical Storm Warning

To avoid a shock hazard, do not connect or disconnect any cables or perform installation, maintenance, or reconfiguration of this product during an electrical storm.

Français: Pour éviter tout risque de choc électrique, ne manipulez aucun câble et n'effectuez aucune opération d'installation, d'entretien ou de reconfiguration de ce produit au cours d'un orage.

Deutsch: Um gefährliche Spannungen zu vermeiden, dürfen während eines Gewitters an diesem Gerät keine Kabel angeschlossen oder gelöst werden, ferner keine Installation, Wartung oder Rekonfiguration durchgeführt werden.

Español: Para evitar peligro de descargas, no conecte o desconecte ningun cable, ni realice ninguna instalación, mantenimiento o reconfiguración de este producto durante una tormenta eléctrica.

Installation Warning

Only personnel knowledgeable in basic electrical and mechanical procedures should install or maintain this equipment.

Français: Seulement le personnel bien informé des procédures électriques et mécaniques de base devrait installer ou mettre à jour ce matériel.

Deutsch: Das nur Personal, das in den grundlegenden elektrischen und mechanischen Prozeduren kenntnisreich ist, sollte diese Ausrüstung installieren oder beibehalten.

Español: Solamente el personal bien informado en procedimientos eléctricos y mecánicos básicos debe instalar o mantener este equipo.

Invisible Laser Radiation Warning

Lasers emit invisible radiation from the aperture opening when no fiber-optic cable is connected. When removing cables do not stare into the open apertures. In addition, install protective aperture covers to fiber ports with no cable connected.

Français: Les lasers émettent le rayonnement invisible de l'ouverture d'ouverture quand aucun câble fiber-optic n'est relié. En enlevant des câbles ne regardez pas fixement dans les ouvertures ouvertes. En outre, installez les couvertures protectrices d'ouverture sur des ports de fibre sans le câble relié.

Deutsch: Laser strahlen unsichtbare Strahlung von der Blendenöffnung Öffnung aus, wenn kein Glasfaserkabel angeschlossen wird. Wenn Sie Kabel löschen, starren Sie nicht in die geöffneten Blendenöffnungen an. Zusätzlich installieren Sie schützende Blendenöffnung Abdeckungen zu den Faserkanälen ohne das angeschlossene Kabel.

Español: Los lasers emiten la radiación invisible de la apertura de la abertura cuando no se conecta ningún cable fiber-optic. Al quitar los cables no mire fijamente en las aberturas abiertas. Además, instale las cubiertas protectoras de la abertura a los accesos de la fibra sin el cable conectado.

Lithium Battery Warning

There is a danger of explosion if the Lithium battery in your chassis is incorrectly replaced. Replace the battery only with the same or equivalent type of battery recommended by the manufacturer. Dispose of used batteries according to the manufacturer's instructions. The manufacturer's instructions are as follows: Return the module with the Lithium battery to Alcatel. The Lithium battery will be replaced at Alcatel's factory.

Français: Il y a un danger d'explosion si la batterie de lithium dans votre châssis est inexactement substituée. Remplacez la batterie seulement avec la même chose ou le type équivalent de batterie recommandé par le constructeur. Rejetez les batteries utilisées selon les instructions du constructeur. Les instructions du constructeur sont comme suit : Renvoyez le module avec la batterie de lithium à Alcatel. La batterie de lithium sera substituée à l'usine d'Alcatel.

Deutsch: Es gibt eine Gefahr der Explosion, wenn die Lithiumbatterie in Ihrem Chassis falsch ersetzt wird. Ersetzen Sie die Batterie nur mit gleichen oder dem gleichwertigen Typen der Batterie empfohlen durch den Hersteller. Entsorgen Sie sich benutzte Batterien entsprechend den Anweisungen des Herstellers. Die Anweisungen des Herstellers sind, wie folgt: Bringen Sie das Modul mit der Lithiumbatterie zu Alcatel zurück. Die Lithiumbatterie wird an der Fabrik Alcatels ersetzt.

Español: Hay un peligro de la explosión si la batería del litio en su chasis se substituye incorrectamente. Sustituya la batería solamente por el mismo o el tipo equivalente de batería recomendado por el fabricante. Disponga de las baterías usadas según las instrucciones del fabricante. Las instrucciones del fabricante son como sigue: Vuelva el módulo con la batería del litio a Alcatel. La batería del litio será substituida en la fábrica de Alcatel.

Dansk: ADVARSEL! Lithiumbatteri--Eksplodingsfare ved fejlagtig håndtering. Udskiftning ma kun ske batteri af samme fabrikat og type. Lever det brugte batteri tilbage tilleverandoren.

Operating Voltage Warning

To reduce the risk of electrical shock, keep your hands and fingers out of power supply bays and do not touch the backplane while the switch is operating.

Français: Pour réduire le risque de choc électrique, gardez vos mains et doigts hors des compartiments d'alimentation d'énergie et ne touchez pas la surface arrière tandis que le commutateur fonctionne.

Deutsch: Um die Gefahr des elektrischen Schlages zu verringern, halten Sie Ihre Hände und Finger aus Spg.Versorgungsteilbuchten heraus und berühren Sie nicht die Rückwandplatine während der Schalter steuert.

Español: Para reducir el riesgo del choque eléctrico, guarde sus manos y dedos fuera de bahías de la fuente de alimentación y no toque la placa madre mientras que el interruptor está funcionando.

Power Disconnection Warning

Your switch is equipped with multiple power supplies. To reduce the risk of electrical shock, be sure to disconnect all power connections before servicing or moving the unit.

Français: Votre commutateur est équipé des alimentations d'énergie multiples. Pour réduire le risque de choc électrique, soyez sûr de débrancher toutes les connexions de puissance avant d'entretenir ou déplacer l'unité.

Deutsch: Ihr Schalter wird mit mehrfachen Spg.Versorgungsteilen ausgerüstet. Um die Gefahr des elektrischen Schlages zu verringern, seien Sie sicher alle Stromanschlüsse zu trennen bevor Sie die Maßeinheit instandhalten oder verschieben.

Español: Su interruptor se equipa de las fuentes de alimentación múltiples. Para reducir el riesgo del choque eléctrico, sea seguro desconectar todas las conexiones de potencia antes de mantener o de mover la unidad.

Proper Earthing Requirement Warning

To avoid shock hazard:

- The power cord must be connected to a properly wired and earth receptacle.
- Any equipment to which this product will attached must also be connected to properly wired receptacles.

Français: Pour éviter tout risque de choc électrique:

- Le cordon d'alimentation doit être branché sur une prise d'alimentation correctement câblée et mise à la terre.
- D'autre part, tout le matériel connecté à ce produit doit également être branché sur des prises d'alimentation correctement câblées et mises à la terre.

Deutsch: Aus Sicherheitsgründen:

- darf das Netzkabel nur an eine Schutzkontaktsteckdose angeschlossen werden.
- dürfen für den Anschluß anderer Geräte an den Drucker auch nur Schutzkontaktsteckdosen verwendet werden.

Español: Para evitar peligro de descargas:

- El cable de alimentación debe estar conectado a una toma de alimentación adecuadamente cableada y con toma de tierra.
- Cualquier equipo al cual se conecte este producto debe estar también conectado a tomas de alimentación adecuadamente cableadas.

Read Important Safety Information Warning

The *Getting Started Guide* that accompanied this equipment contains important safety information about which you should be aware when working with hardware components in this system. You should read this guide before installing, using, or servicing this equipment.

Français: Le *Getting Started Guide* qui a accompagné ce matériel contient l'information importante de sûreté au sujet dont vous devriez vous rendre compte en travaillant avec des composants de matériel dans ce système. Vous devriez lire ce guide avant d'installer, à l'aide, ou entretenir de ce matériel.

Deutsch: Die *Getting Started Guide*, die diese Ausrüstung begleitete, enthält wichtige Sicherheit Informationen, über die Sie beim Arbeiten bewußt sein sollten mit Hardwareeinheiten in diesem System. Sie sollten diese Anleitung lesen, bevor Sie installieren, verwenden, oder instandhalten diese Ausrüstung.

Español: La *Getting Started Guide* que acompañó este equipo contiene la información importante de seguridad sobre la cual usted debe estar enterado al trabajar con los componentes de dotación física en este sistema. Usted debe leer esta guía antes de instalar, de usar, o de mantener este equipo.

Restricted Access Location Warning

This equipment should be installed in a location that restricts access. A restricted access location is one where access is secure and limited to service personnel who have a special key, or other means of security.

Français: Ce matériel devrait être installé dans un emplacement qui limite l'accès. Un emplacement restreint d'accès est un où l'accès est bloqué et limité au personnel de service qui ont une clé spéciale, ou à d'autres moyens de sécurité.

Deutsch: Diese Ausrüstung sollte in einen Standort installiert werden, der Zugriff einschränkt. Ein eingeschränkter Zugriff Standort ist einer, wo Zugriff befestigen und an Service-Personal, das eine spezielle Taste haben, oder an andere Mittel der Sicherheit begrenzt ist.

Español: Este equipo se debe instalar en una localización que restrinja el acceso. Una localización restringida del acceso es una donde está seguro y limitado el acceso al personal de servicio que tiene un clave especial, o a otros medios de la seguridad.

Wrist Strap Warning

Because electrostatic discharge (ESD) can damage switch components, you must ground yourself properly before continuing with the hardware installation. For this purpose, Alcatel provides a grounding wrist strap and a grounding lug located near the top-right of the chassis. For the grounding wrist strap to be effective in eliminating ESD, the power supplies must be installed in the chassis and plugged into grounded AC outlets.

Français: Puisque la décharge électrostatique (ESD) peut endommager des composants de commutateur, vous devez vous rectifier correctement avant de continuer l'installation de matériel. À cette fin, Alcatel fournit une courroie de poignet fondante et une patte de mise à la terre située près du dessus-droit du châssis. Pour que la courroie de poignet fondante soit pertinente en éliminant ESD, les alimentations d'énergie doivent être installées dans le châssis et être branchées aux sorties au sol à C.A.

Deutsch: Weil elektrostatische Entladung (ESD) Schalterbestandteile beschädigen kann, müssen Sie richtig sich reiben, bevor Sie mit der Hardwareinstallation fortfahren. Zu diesem Zweck stellt Alcatel eine erdenhandgelenkbrücke und eine Erdungsöse zur Verfügung, die nahe dem Oberseite-rechten des Chassis gelegen sind. Damit die erdenhandgelenkbrücke wirkungsvoll ist, wenn man ESD beseitigt, die Spg.Versorgungsteile muß in das Chassis installiert werden und eingesteckt werden in geerdete Wechselstrom Anschlüsse.

Español: Porque la descarga electrostática (ESD) puede dañar componentes del interruptor, usted debe molerse correctamente antes de continuar con la instalación de dotación física. Para este propósito, Alcatel proporciona a una correa de muñeca que pone a tierra y a un terminal que pone a tierra situados cerca del tapa-derecho del chasis. Para que la correa de muñeca que pone a tierra sea eficaz en la eliminación de ESD, las fuentes de alimentación se deben instalar en el chasis y tapar en los enchufes puestos a tierra de la CA.

Instrucciones de seguridad en español

Advertencia sobre el levantamiento del chasis

Se requieren dos personas para levantar el chasis. Debido a su peso, la elevación del chasis sin ayuda puede causar daños corporales. También es seguro doblar sus rodillas y guardar su espalda derecho al ayudar a levantar el chasis.

Advertencia de las tapaderas en blanco

Porque regulan la circulación de aire y ayudan a proteger componentes internos del chasis, las tapaderas en blanco deben seguir instaladas en las ranuras vacías del módulo y la fuente de alimentación siempre.

Advertencia en caso de tormenta eléctrica

Para evitar peligro de descargas, no conecte o desconecte ningún cable, ni realice ninguna instalación, mantenimiento o reconfiguración de este producto durante una tormenta eléctrica.

Advertencia de instalación

Solamente el personal bien informado en procedimientos eléctricos y mecánicos básicos debe instalar o mantener este equipo.

Advertencia de radiación láser invisible

Los lasers emiten radiación invisible de la apertura abierta cuando no se conecta ningún cable de fibra óptica. Al quitar los cables no mire fijamente en las aberturas abiertas. Además, instale las cubiertas protectoras de la apertura a las salidas de la fibra sin el cable conectado.

Advertencia de la batería de litio

Hay un peligro de la explosión si la batería del litio en su chasis se substituye incorrectamente. Substituya la batería solamente por el mismo o el equivalente de tipo de batería recomendado por el fabricante. Deseche las baterías usadas según las instrucciones del fabricante. Las instrucciones del fabricante son como sigue: Devuelva el módulo con la batería del litio a Alcatel. La batería del litio será substituida en la fábrica de Alcatel.

Advertencia sobre la tensión de operación

Para reducir el riesgo del choque eléctrico, mantenga sus manos y dedos fuera de la fuente de alimentación y no toque la placa madre mientras que el interruptor está funcionando.

Advertencia sobre la desconexión de la fuente

Su interruptor esta equipado por fuentes de alimentación múltiples. Para reducir el riesgo de choque eléctrico, asegúrese desconectar todas las conexiones de alimentación antes de mantener o de mover la unidad.

Advertencia sobre una apropiada conexión a tierra

Para evitar peligro de descargas:

- El cable de alimentación debe estar conectado a una toma de alimentación adecuadamente cableada y con toma de tierra.

Cualquier equipo al cual se conecte este producto debe estar también conectado a tomas de alimentación adecuadamente cableadas.

Leer “información importante de seguridad”

La *Guía de “Comenzando a Usar”* que acompaña este equipo contiene información importante de seguridad sobre la cual usted debe saber al trabajar con los componentes de dotación física en este sistema. Usted debe leer esta guía antes de instalar, de usar, o de mantener este equipo.

Advertencia de acceso restringido

Este equipo se debe instalar en una ubicación que restrinja el acceso. Una ubicación con acceso restringido es una donde está seguro y limitado el acceso al personal de servicio que tiene un clave especial, u otros medios de la seguridad.

Advertencia de pulsera antiestática

Debido a que la descarga electrostática (ESD) puede dañar componentes del interruptor, usted debe conectarse a tierra correctamente antes de continuar con la instalación del equipo. Para este propósito, Alcatel proporciona una pulsera antiestática y un terminal que pone a tierra situados cerca de la parte superior derecha del chasis. Para que la pulsera antiestática sea eficaz en la eliminación de ESD, las fuentes de alimentación se deben instalar en el chasis y enchufar en las salidas de CA con descarga a tierra.

Clase de seguridad

Cumple con 21CFR 1040.10 y 1040.11 ó sus equivalentes.

Advertencia de fuentes de poder

Las unidades OmniSwitch 8800 pueden estar equipadas con cuatro cordones para fuente de poder. Para reducir el riesgo de un choque eléctrico, desconecte todos los cordones de fuente de poder antes de dar servicio a la unidad.

Index

Numerics

- 10GNI modules
 - features 5-18
 - OS8-10GNI-UR1 5-18, 5-20

A

- airflow
 - chassis 2-35
 - power supply 2-37
- availability 1-3
 - hardware monitoring 1-5
 - hardware redundancy 1-3
 - hot swapping 1-5
 - power checking 1-6
 - Smart Continuous Switching 1-4
 - software rollback 1-4

B

- blank cover plates
 - airflow and 2-38

C

- chassis
 - airflow 2-8, 2-35
 - blank cover plates 2-38
 - fan tray 2-28
 - installing 2-8
 - MAC address 3-17
 - personal grounding lug 5-29
 - rack-mounting 2-9
 - slot numbering 2-6
 - standalone 2-9
 - supplemental ground 2-26
 - temperature management 2-26
- Chassis Management Module
 - see* CMM
- chassis temperature
 - monitoring 2-26
- CLI commands
 - supported on secondary CMM 3-16
- CMM 3-1
 - commands supported on secondary 3-16
 - console/modem port 3-3, 3-5
 - Ethernet Management Port 3-3, 3-4
 - failover 3-9
 - front panel 3-3
 - hot swapping 3-12
 - LEDs 3-3
 - managing 3-13

- monitoring 3-15
 - primary 3-9
 - redundancy 3-9
 - reloading 3-13
 - secondary 3-9
 - slot locations 3-2
 - switching the primary and secondary roles 3-14
 - synchronizing primary and secondary 3-10
 - technical specifications 2-28, 3-4
- console port
 - modifying 3-7
 - console/modem port 3-5
 - default settings 3-5
 - modifying 3-5, 3-7
 - copy flash-synchro** command 3-11

E

- ENI modules
 - features 5-3
 - OS8-ENI-C24 5-3, 5-4
- Ethernet Management Port (EMP) 3-4
 - default IP address 3-4

F

- fan tray 2-28
 - fan redundancy 2-30
 - hot swapping 2-31
 - installing 2-32, 2-34
 - monitoring 2-30
 - removing 2-31, 2-33
 - technical specifications 2-28
- fans
 - chassis 2-28
 - power supplies 2-37
 - redundancy 2-30
- fiber
 - handling 5-35

G

- GNI modules
 - features 5-6
 - high-density modules 5-6
 - OS8-GNI2-C24 5-16
 - OS8-GNI2-U24 5-11
 - OS8-GNI-C24 5-16
 - OS8-GNI-C8 5-6, 5-7
 - OS8-GNI-U24 5-11
 - OS8-GNI-U8 5-6, 5-9
 - wire-rate modules 5-6
- grounding lug 5-29

H

- hardware monitoring 1-5
 - automatic 1-5
 - LEDs 1-5, 3-3, 4-3, 5-4, 5-7, 5-9, 5-11, 5-16, 5-20
 - user-driven 1-5

hot swapping 1-5
 CMMs 1-5
 fan tray 1-5
 NI modules 1-5
 power supplies 1-5

I

image rollback
see software rollback

J

jumbo frames 5-8, 5-10, 5-12, 5-17, 5-21

L

LEDs
see hardware monitoring

M

MAC address ranges
 multiple MAC router mode and 2-41
 VLAN router ports and 2-41
 MiniGBICs 5-13
 installing 5-14, 5-15
 MiniGBIC-LH-70 5-13
 MiniGBIC-LX 5-13
 MiniGBIC-SX 5-13
 technical specifications 5-13
 multiple MAC router mode 2-41

N

Network Interface Modules
see NI modules
 NI modules
 boot sequence 1-6, 5-26
 handling fiber 5-35
 hot swapping 5-28
 installing 5-30
 locations 5-30
 managing 5-26
 monitoring 5-27
 OS8-10GNI-UR1 5-20
 OS8-ENI-C24 5-4
 OS8-GNI2-C24 5-16
 OS8-GNI2-U24 5-11
 OS8-GNI-C24 5-16
 OS8-GNI-C8 5-7
 OS8-GNI-U24 5-11
 OS8-GNI-U8 5-9
 pinouts 3-18, 5-30, 5-34
 power checking 1-6
 powering on or off 5-26
 reloading 5-26
 removing and adding 5-29
 technical specifications 5-5, 5-8, 5-10, 5-12, 5-17, 5-21
no power ni command 5-26

O

OmniSwitch 8800 1-1
 application examples 1-2
 technical specifications 2-5, 2-14, 2-16
 OS8-10GNI-UR1 5-20
 front panel 5-20
 LEDs 5-20
 port redundancy 5-19
 ports 5-20
 technical specifications 5-21
 unsupported software 5-19
 OS8-ENI-C24 5-4
 front panel 5-4
 LEDs 5-4
 ports 5-4
 technical specifications 5-5
 OS8-GNI2-C24 5-16
 front panel 5-16
 LEDs 5-16
 ports 5-16
 technical specifications 5-17
 OS8-GNI2-U24 5-11
 front panel 5-11
 LEDs 5-11
 ports 5-11
 technical specifications 5-12
 OS8-GNI-C24 5-16
 front panel 5-16
 LEDs 5-16
 ports 5-16
 technical specifications 5-17
 OS8-GNI-C8 5-7
 front panel 5-7
 LEDs 5-7
 ports 5-7
 technical specifications 5-8
 OS8-GNI-U24 5-11
 front panel 5-11
 LEDs 5-11
 ports 5-11
 technical specifications 5-12
 OS8-GNI-U8 5-9
 front panel 5-9
 LEDs 5-9
 ports 5-9
 technical specifications 5-10

P

power checking
see NI modules
 power cords 2-24
power ni command 5-26

- power supplies 2-13, 2-15
 - airflow 2-37
 - fans 2-37
 - installing 2-19
 - monitoring 2-17
 - power cords 2-24
 - redundancy 2-13, 2-15
 - redundant AC circuits and 2-25
 - removing 2-22
 - technical specifications 2-14, 2-16

R

- redundancy 1-3
 - AC circuit 2-25
 - CMM 3-9
 - commands supported on secondary CMM 3-16
 - fans 2-30
 - hardware 1-3
 - MAC EEPROM 3-17
 - power supplies 2-13, 2-15
 - SFM 4-4
- reload** command 3-13
- reload ni** command 5-26

S

- session xon-xoff** command 3-7
- SFM
 - failover 4-4
 - front panel 4-3
 - hot swapping 4-5
 - LEDs 4-3
 - monitoring 4-14
 - primary 4-4
 - redundancy 4-4
 - secondary 4-4
 - slot locations 4-2
 - technical specifications 4-3
- show cmm** command 3-15
- show fan** command 2-27, 2-30
- show hardware info** command 3-16
- show module** command 2-7
- show module long** command 2-7
- show ni** command 5-27
- show power** command 2-17
- show running-directory** command 3-14
- show temperature** command 2-26, 2-27
- slot numbering 2-6
- Smart Continuous Switching 1-4, 5-26
- software rollback 1-4

T

- takeover** command 3-14
- technical specifications
 - CMM 2-28, 3-4
 - fans 2-28
 - MiniGBICs 5-13
 - NI modules 5-5, 5-8, 5-10, 5-12, 5-17, 5-21
 - OmniSwitch 8800 2-5
 - power supplies 2-14, 2-16
 - SFM 4-3
 - Xenpaks 5-22
- temperature management 2-26
 - danger threshold 2-27
 - errors 2-27
 - warning threshold 2-27
- temp-threshold** command 2-27

X

- Xenpaks 5-22
 - installing 5-23, 5-25
 - OM-10GNI-ER 5-22
 - OM-10GNI-LR 5-22
 - OM-10GNI-SR 5-22
 - technical specifications 5-22

